



Yulee High School

Course Catalog 2024-2025

85375 Miner Rd.
Yulee, FL 32097
904-225-8641

Table of Contents

Course Offerings.....	3
Graduation Requirements.....	4
English Course Sequence.....	8
Mathematics Course Sequence.....	9
Science Course Sequence.....	10
Social Studies Sequence.....	11
Art.....	12
Electives.....	21
English.....	26
Foreign Language.....	28
Mathematics.....	30
Physical Education.....	33
Science.....	36
Social Studies	39
Vocational.....	42

*Please see the Nassau County School District Student Progression plan for guidelines outline policies and procedures adopted by the Nassau County School Board.

<https://www.nassau.k12.fl.us/Page/114>

Course Offerings

Advanced Placement Courses

AP Computer Science A
AP Computer Science Principles
AP Chemistry
AP English Language and Composition
AP English Literature and Composition
AP Environmental Science
AP World History
AP Human Geography
AP Macroeconomics
AP Precalculus
AP Psychology
AP US Government and Politics
AP United States History

Foreign Languages

Spanish

French

Vocational Courses

Air Conditioning, Refrigeration, and Heating Technology
Architectural Drafting
Auto Maintenance /LT Repair
Business Management and Administration
Culinary Arts
Health Science
Java Development and Programming
Game Simulation Animation Programming

On-Campus Dual Enrollment

AMH2010 United State History to 1877
AMH2020 United State History from 1877
BSC2010C General Biology
BSC2020C Principles of Biology 2
ENC1101 Freshman English 1
ENC1102 Freshman English 2
LIT2000 Literature in the Humanities
MAC1105 College Algebra
SLS1103 Strategies for College Success
STA2023 Statistical Methods 1

English Language Arts Sequence

Four credits required for graduation.

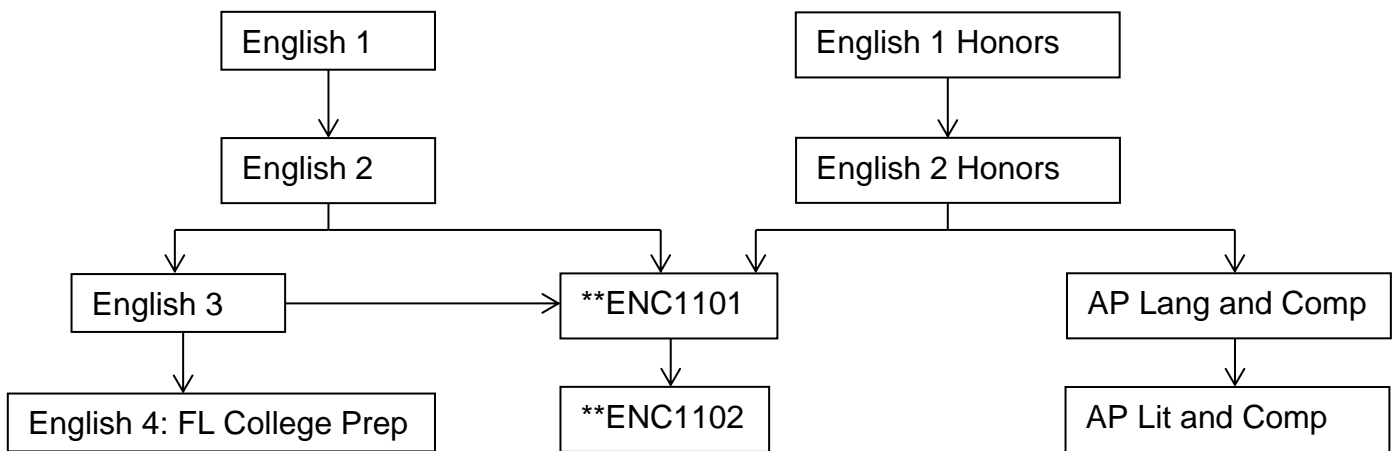

*Student placement is based off of ELA FSA scores for the prior school year.

** Students must meet the criteria outlined in the Dual Enrollment Articulation Agreement between Florida State College of Jacksonville and the Nassau County School District.

Mathematics Sequence

Four credits required for graduation with two credits consisting of Algebra 1 and Geometry.

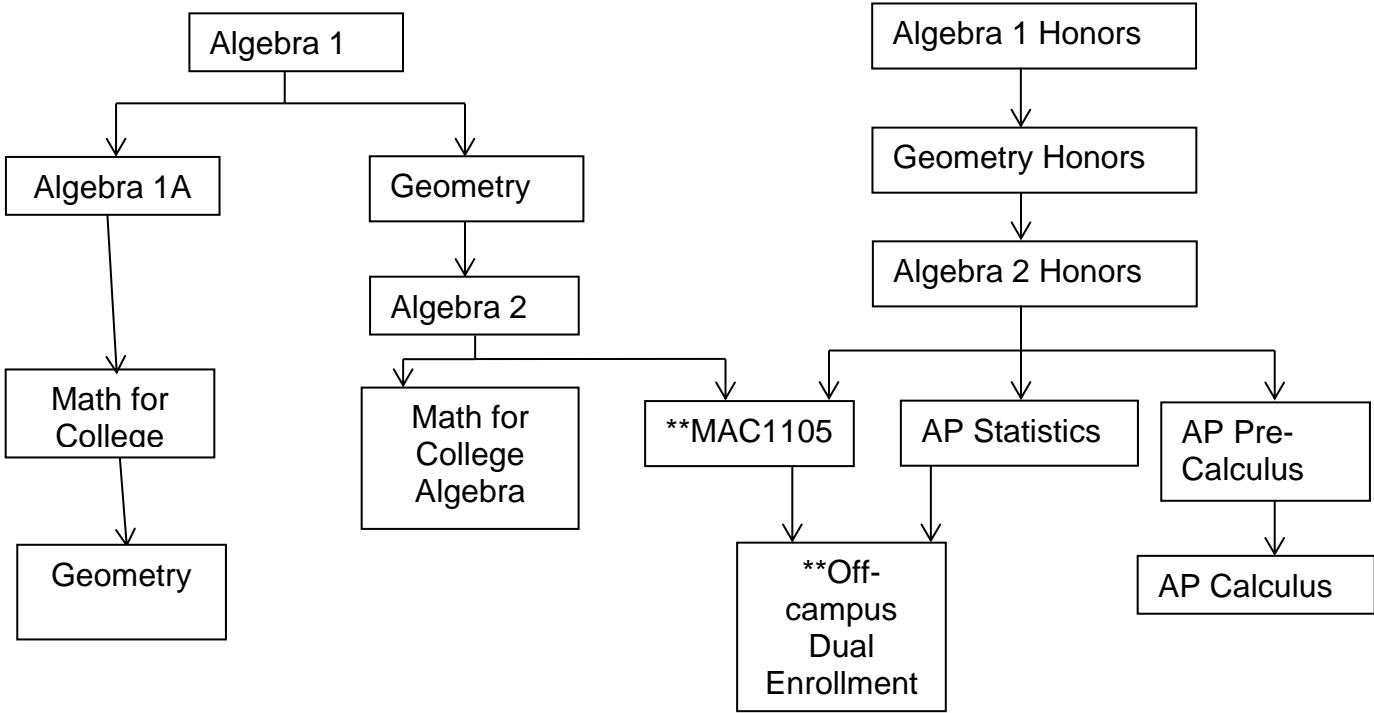

*Student placement is based off of FSA scores in Mathematics, Algebra 1 EOC, or Geometry EOC for the prior school year.

** Students must meet the criteria outlined in the Dual Enrollment Articulation Agreement between Florida State College of Jacksonville and the Nassau County School District.

Science Sequence

Three credits required for graduation consisting of one credit in Biology and two must be considered equally rigorous science courses.

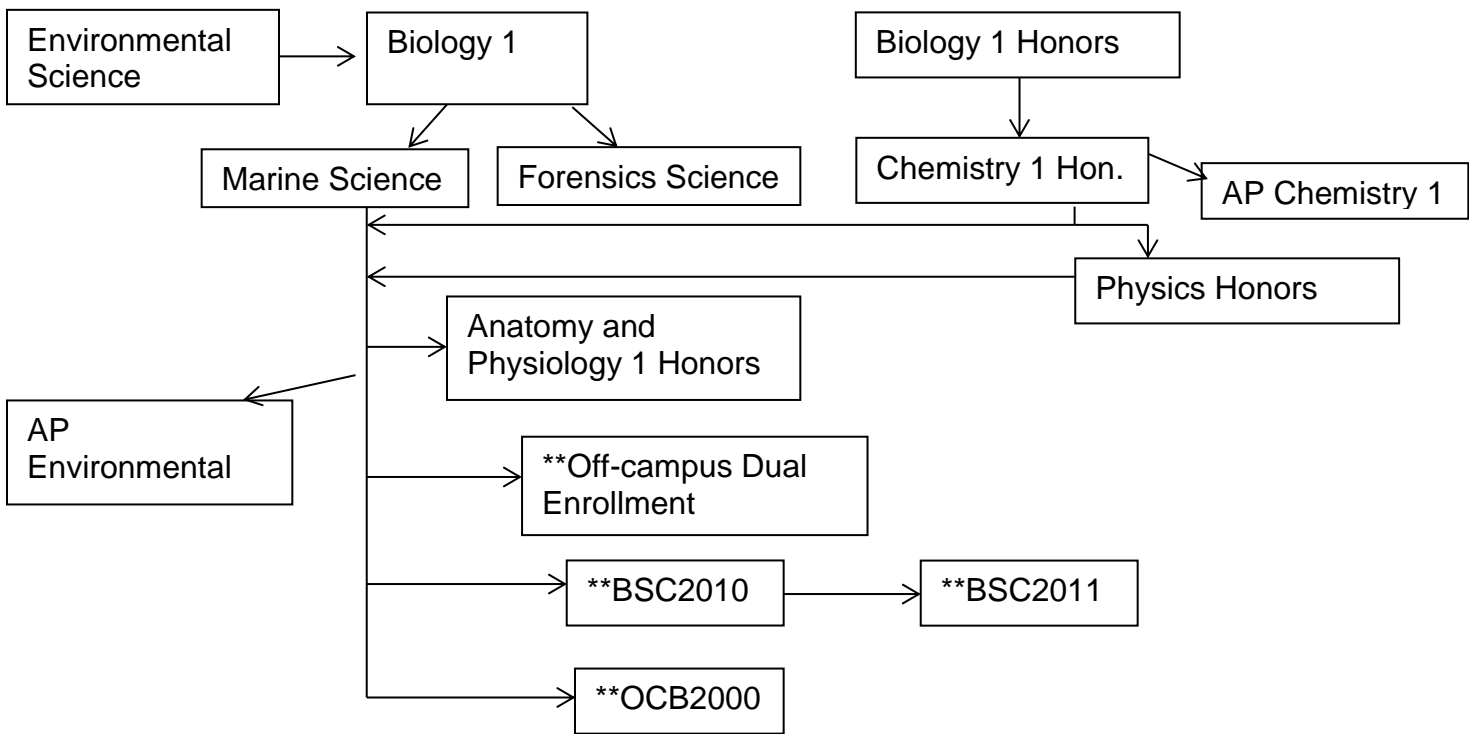

*Student placement is based off of ELA FSA scores for the prior school year.

** Students must meet the criteria outlined in the Dual Enrollment Articulation Agreement between Florida State College of Jacksonville and the Nassau County School District.

Social Studies Sequence

One credit in World History, one credit in US History, .5 credit in Economics with Financial Literacy, and .5 credit in American Government.

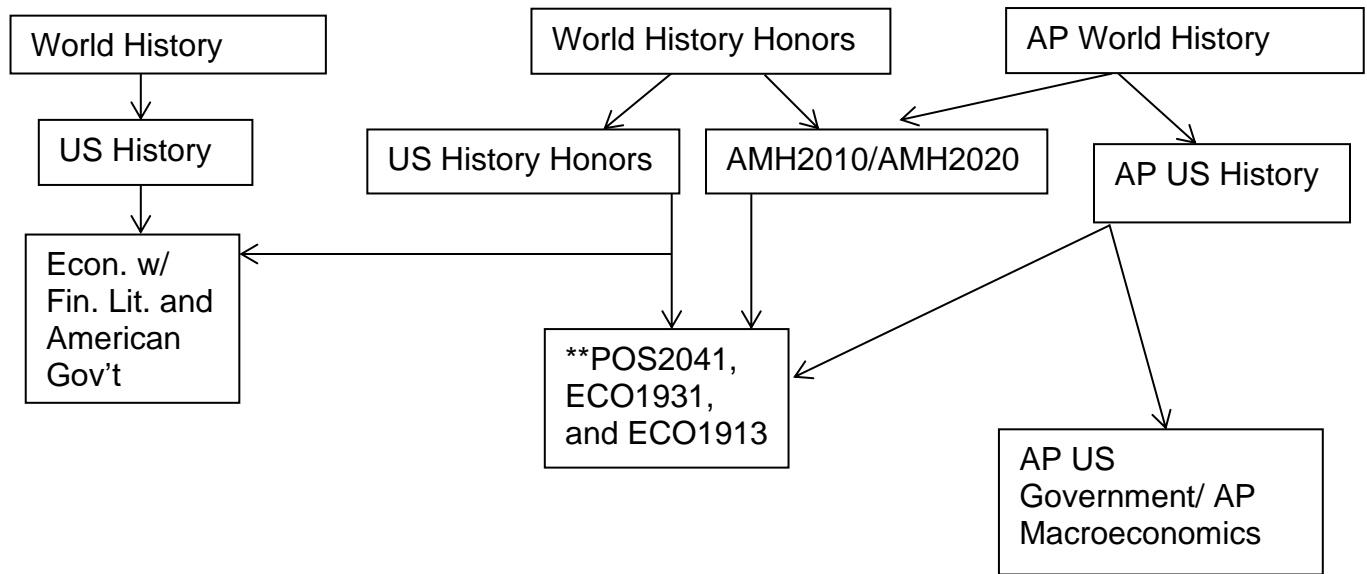

*Student placement is based off of ELA FSA scores for the prior school year.

** Students must meet the criteria outlined in the Dual Enrollment Articulation Agreement between Florida State College of Jacksonville and the Nassau County School District.

Art

Course Number: 0101300

Course Title: 2-D Studio Art 1

Credit: 1.0

Graduation Requirement: Performing Fine Art

Description: Students experiment with the media and techniques used to create a variety of two-dimensional (2-D) artworks through the development of skills in drawing, painting, printmaking, collage, and/or design. Students practice, sketch, and manipulate the structural elements of art to improve mark making and/or the organizational principles of design in a composition from observation, research, and/or imagination. Through the critique process, students evaluate and respond to their own work and that of their peers. This course incorporates hands-on activities and consumption of art materials.

Link to CPALMS: <http://www.cpalms.org/Public/PreviewCourse/Preview/945>

Course Number: 0101310

Course Title: 2-D Studio Art 2

Credit: 1.0

Graduation Requirement: Performing Fine Art

Description: Students develop and refine technical skills and create 2-D compositions with a variety of media in drawing, painting, printmaking, collage, and/or design. Student artist sketch, manipulate, and refine the structural elements of art to improve mark-making and/or the organizational principles of design in a composition from observation, research, and/or imagination. Through the critique process, students evaluate and respond to their own work and that of their peers. This course incorporates hands-on activities and consumption of art materials.

Link to CPALMS: <http://www.cpalms.org/Public/PreviewCourse/Preview/946>

Course Number: 0101330

Course Title: Art 3-D Studio

Credit: 1.0

Graduation Requirement: Performing Fine Art

Description: Students explore how space, mass, balance, and form combine to create aesthetic forms or utilitarian products and structures. Instruction may include, but is not limited to, content in green or industrial design, sculpture, ceramics, or building arts. Media may include, but are not limited to, clay, wood, plaster, and paper maché with consideration of the workability, durability, cost, and toxicity of the media used. Student artists consider the relationship of scale (i.e., hand-held, human, monumental) through the use of positive and negative space or voids, volume, visual weight, and gravity to create low/high relief or freestanding structures for personal intentions or public places. They explore sharp and diminishing detail, size, position, overlapping, visual pattern, texture, implied line, space, and plasticity, reflecting craftsmanship and quality in the surface and structural qualities of the completed art forms. Students in the 3-D art studio focus on use of safety procedures for process, media, and techniques. Student artists use an art criticism process to evaluate, explain, and measure artistic growth in personal or group works. This course incorporates hands-on activities and consumption of art materials.

Link to CPALMS: <http://www.cpalms.org/Public/PreviewCourse/Preview/949>

Course Number: 0400370

Course Title: Acting 1

Credit: 1.0

Graduation Requirement: Performing Fine Art

Description: Through improvisation, simple scripted scenes, performance projects, and/or practical application, students learn to identify what makes performances believable and explore the tools used to create, articulate, and execute them. Upon completion of this course, students have a strong foundation for future scene work, script analysis, and play production. Public performances may serve as a culmination of specific instructional goals. Students may be required to attend and/or participate in rehearsals and performances outside the school day to support, extend, and assess learning in the classroom.

Link to CPALMS: <http://www.cpalms.org/Public/PreviewCourse/Preview/4061>

Course Number: 0400380

Course Title: Acting 2

Credit: 1.0

Graduation Requirement: Performing Fine Art

Description: Students examine the various dimensions of characters through analysis, discussion, and classroom performance, working with scripts from a variety of time periods and cultures. They learn to break down a scene from a character's point of view, and also learn to sustain a character and build the relationship between actor and audience. Public performances may serve as a culmination of specific instructional goals. Students may be required to attend and/or participate in rehearsals and performances outside the school day to support, extend, and assess learning in the classroom.

Link to CPALMS: <http://www.cpalms.org/Public/PreviewCourse/Preview/1097>

Course Number: 0400390

Course Title: Acting 3

Credit: 1.0

Graduation Requirement: Performing Fine Art

Description: Students focus on development of significant acting skills and knowledge of the actor's literature, compiling a working actor's portfolio for exhibition and/or the interview process. They research potential job opportunities in the film, television, game animation, and theatre industries, as well as scholarships and opportunities available at the university level. An inquiry-based capstone project may be required. Public performances may serve as a culmination of specific instructional goals. Students may be required to participate in rehearsals and performances outside the school day to support, extend, and assess learning in the classroom.

Link to CPALMS: <http://www.cpalms.org/Public/PreviewCourse/Preview/1098>

Course Number: 0400400

Course Title: Acting 4 Hon

Credit: 1.0

Graduation Requirement: Performing Fine Art

Description: Students create characters for theatrical and film/video productions through scene, character, and technical analysis. Through improvisation, script writing, and aesthetic creation and collaboration, actors refine their working knowledge and independent thought, articulating and justifying their creative choices. Students' "critical eye" becomes more developed and significant mastery of artistic choices becomes evident. An inquiry-based capstone project may be required. Public performances may serve as a culmination of specific instructional goals. Students may be required to participate in rehearsals and performances outside the school day to support, extend, and assess learning in the classroom.

Link to CPALMS: <http://www.cpalms.org/Public/PreviewCourse/Preview/1099>

Course Number: 0100330

Course Title: Art History 1 Hon.

Credit: 1

Graduation Requirement: Performing Fine Art

Description: Students explore the role of art in history and culture through observation and analysis of significant works of art and architecture from Prehistory through the 16th century. Student historians investigate the societal context of works, considering traditional forms and conventions of representation, symbology, and the purposes for which the art was created. The course includes an introduction to the methodologies of art history and criticism, study of the media and techniques used by artists from various cultures and time periods, and use of appropriate terminology in verbal and written analyses of artworks drawn from around the world. Student historians critique and compare works across time and cultures to develop an understanding of, and respect for, the visual arts as a chronicle of history, cultural heritage, and the human experience. This course may incorporate hands-on activities and consumption of art materials.

Link to CPALMS: <http://www.cpalms.org/Public/PreviewCourse/Preview/4654>

Course Number: 0100340

Course Title: Art History 2 Hon.

Credit: 1

Graduation Requirement: Performing Fine Art

Description: Students explore art and architecture as an expressive response to the artist's experience. Through research and analysis of significant works and their historical contexts students examine changes in the understanding and structures of art production throughout the world. Students examine influential factors, such as people and events, societal and political changes, technological advancements, philosophical ideas, and cross-cultural influences as a means of discovering and tracing the changing definition of art. Student historians research and write about art using appropriate discipline-based methods (i.e., historical, critical, and aesthetic). This course may incorporate hands-on activities and consumption of art materials.

Link to CPALMS: <http://www.cpalms.org/Public/PreviewCourse/Preview/943>

Course Number: 1302300

Course Title: Band 1

Credit: 1.0

Graduation Requirement: Performing Fine Art

Description: This year-long, entry-level class, designed for students having little or no previous band experience with woodwind, brass, and/or percussion instruments, promotes the enjoyment and appreciation of music through performance of high-quality, beginning wind and percussion literature from different times and places. Rehearsals focus on the development of critical listening/aural skills; rudimentary instrumental technique and skills, music literacy, and ensemble skills; and aesthetic musical awareness culminating in periodic public performances.

Link to CPALMS: <http://www.cpalms.org/Public/PreviewCourse/Preview/1392>

Course Number: 1302310

Course Title: Band 2

Credit: 1.0

Graduation Requirement: Performing Fine Art

Description: This year-long, beginning-level class, designed for students with at least one year of woodwind, brass, and/or percussion ensemble experience, promotes the enjoyment and appreciation of music through performance of high-quality wind and percussion literature. Rehearsals focus on the development of critical listening skills, instrumental and ensemble technique and skills, expanded music literacy, and aesthetic awareness culminating in periodic public performances.

Link to CPALMS: <http://www.cpalms.org/Public/PreviewCourse/Preview/4006>

Course Number: 1302320

Course Title: Band 3

Credit: 1.0

Graduation Requirement: Performing Fine Art

Description: This year-long, formative class, designed for students ready to build on skills and knowledge previously acquired in a middle or high school instrumental ensemble, promotes the enjoyment and appreciation of music through performance of high-quality, intermediate-level wind and percussion literature. Rehearsals focus on development of critical listening/aural skills, individual musicianship, instrumental technique, refinement of ensemble skills, and aesthetic engagement culminating in periodic public performances.

Link to CPALMS: <http://www.cpalms.org/Public/PreviewCourse/Preview/4010>

Course Number: 1302330

Course Title: Band 4

Credit: 1.0

Graduation Requirement: Performing Fine Art

Description: This year-long, intermediate-level course, designed for students who demonstrate proficiency in woodwind, brass and/or percussion techniques, music literacy, critical listening/aural skills, and ensemble performance skills, promotes greater engagement with and appreciation for music through performance and other experiences with a broad spectrum of music, as well as creativity through composition and/or arranging.. Study includes cultivation of well-developed instrumental ensemble techniques and skills, music literacy and theory, and deeper aesthetic engagement with a wide variety of high-quality repertoire.

Link to CPALMS: <http://www.cpalms.org/Public/PreviewCourse/Preview/4017>

Course Number: 1302340

Course Title: Band 5 Hon

Credit: 1.0

Graduation Requirement: Performing Fine Art

Description: This year-long, advanced course, designed for wind and percussion students with extensive experience in solo performance and larger performing ensembles, promotes significant depth of engagement and lifelong appreciation of music through performance and other experiences with sophisticated instrumental music, as well as creativity through composition and/or

arranging. The course includes the development of advanced instrumental ensemble techniques and skills, extended music literacy and theory, and deep aesthetic engagement with a broad spectrum of high-quality repertoire, ranging from early music to the contemporary. Musical independence and leadership are particularly encouraged in this setting.

Link to CPALMS: <http://www.cpalms.org/Public/PreviewCourse/Preview/1396>

Course Number: 1302350

Course Title: Band 6 Hon

Credit: 1.0

Graduation Requirement: Performing Fine Art

Description: This year-long, highly advanced course, designed for students with substantial experience in solo performance and larger performing ensembles, promotes significant engagement with and appreciation for music through performance of sophisticated wind and percussion literature. Study focuses on mastery of highly advanced music skills, techniques, and processes, as well as creativity through composition and/or arranging and use of current technology to enhance creativity and performance effectiveness. This course also provides significant opportunities for student leadership through peer mentoring, solo work, and participation as a performer or coach in a small or large ensemble.

Link to CPALMS: <http://www.cpalms.org/Public/PreviewCourse/Preview/1397>

Course Number: 0102300

Course Title: Ceramics/Pottery 1

Credit: 1.0

Graduation Requirement: Performing Fine Art

Description: Students explore how space, mass, balance, and form combine to create aesthetic forms or utilitarian products and structures. Instructional focus will be on ceramics and/or pottery. Media may include, but are not limited to, clay and/or plaster, with consideration of the workability, durability, cost, and toxicity of the media used. Student artists consider the relationship of scale (i.e., hand-held, human, monumental) through the use of positive and negative space or voids, volume, visual weight, and gravity to create low/high relief or freestanding structures for personal intentions or public places. They explore sharp and diminishing detail, size, position, overlapping, visual pattern, texture, implied line, space, and plasticity, reflecting craftsmanship and quality in the surface and structural qualities of the completed art forms. Students in the ceramics and/or pottery art studio focus on use of safety procedures for process, media, and techniques. Student artists use an art criticism process to evaluate, explain, and measure artistic growth in personal or group works. This course incorporates hands-on activities and consumption of art materials.

Link to CPALMS: <http://www.cpalms.org/Public/PreviewCourse/Preview/4798>

Course Number: 0102310

Course Title: Ceramics/Pottery 2

Credit: 1.0

Graduation Requirement: Performing Fine Art

Description: Students explore spatial relationships through the use of nonobjective, abstract, or representational forms, products, or structures. Instructional focus should be on ceramics and/or pottery. Processes and techniques for substitution may include, but are not limited to, wheel-thrown clay, glaze formulation and application. Media may include, but are not limited to, clay and/or plaster with consideration of the workability, durability, cost, and toxicity of the media used. Ceramic and/or pottery artists experiment with and manipulate space-producing devices, including overlapping, transparency, interpenetration, vertical and horizontal axis, inclined planes, disproportionate scale, fractional or abstracted representation, and spatial properties of the structural art elements. Craftsmanship and quality are reflected in the surface and structural qualities of the completed art forms. Students in the ceramics and/or pottery art studio focus on use of safety procedures for process, media, and techniques. Student artists use an art criticism process to evaluate, explain, and measure artistic growth in personal or group works. This course incorporates hands-on activities and consumption of art materials.

Link to CPALMS: <http://www.cpalms.org/Public/PreviewCourse/Preview/4796>

Course Number: 1303300

Course Title: Chorus 1

Credit: 1.0

Graduation Requirement: Performing Fine Art

Description: This year-long, entry-level class, designed for students with little or no choral experience, promotes the enjoyment and appreciation of music through performance of beginning choral repertoire from a variety of times and places. Rehearsals focus on the development of critical listening skills; foundational instrumental technique and skills, music literacy, and ensemble skills; and aesthetic musical awareness culminating in periodic public performances.

Link to CPALMS: <http://www.cpalms.org/Public/PreviewCourse/Preview/4062>

Course Number: 1303310

Course Title: Chorus 2

Credit: 1.0

Graduation Requirement: Performing Fine Art

Description: This year-long, beginning-level class, designed for students with one year of experience or less in a choral performing group, promotes the enjoyment and appreciation of music through performance of basic, high-quality choral music. Rehearsals focus on the development of critical listening/aural skills; foundational instrumental technique and skills, music literacy, and ensemble skills; and aesthetic musical awareness culminating in periodic public performances.

Link to CPALMS: <http://www.cpalms.org/Public/PreviewCourse/Preview/4065>

Course Number: 1303320

Course Title: Chorus 3

Credit: 1.0

Graduation Requirement: Performing Fine Art

Description: This year-long, formative class, designed for students with previous participation in a school chorus who have basic knowledge of note-reading and vocal technique, concentrates on providing students opportunities to strengthen existing skills in critical listening, vocal techniques, and ensemble performance using high-quality three- and four-part choral literature. Rehearsals focus on gaining independence in music literacy and aesthetic engagement through critical listening and thinking skills.
<http://www.cpalms.org/Public/PreviewCourse/Preview/13876?isShowCurrent=false>

Link to CPALMS: <http://www.cpalms.org/Public/PreviewCourse/Preview/13876?isShowCurrent=false>

Course Number: 1303330

Course Title: Chorus 4

Credit: 1.0

Graduation Requirement: Performing Fine Art

Description: This year-long, intermediate-level class is designed for students with previous participation in a high school chorus and moderate skills in critical listening, vocal techniques, music literacy, and choral performance. Rehearsals focus on enhancing these skills and students' aesthetic engagement with music through a variety of high-quality three- and four-part choral literature, providing students with the means to learn how to reflect and use a combination of analytical, assessment, and problem-solving skills consistently to improve their own and others' performance.

Link to CPALMS: <http://www.cpalms.org/Public/PreviewCourse/Preview/1421>

Course Number: 1007330

Course Title: Debate 1

Credit: 1.0

Graduation Requirement: Performing Fine Art

Description: This course is focused on the use of correct and effective language and organizational skills in preparing, delivering, and evaluating argument and debate. Students will critique debates, paying attention to content, organization, language, and delivery style, and produce and present well-structured, developed arguments, applying oral communication concepts and strategies for public debate in a variety of given settings.

Link to CPALMS: <http://www.cpalms.org/Public/PreviewCourse/Preview/1640>

Course Number: 0104340

Course Title: Drawing 1

Credit: 1.0

Graduation Requirement: Performing Fine Art

Description: Students experiment with the media and techniques used to create a variety of two-dimensional (2-D) artworks through the development of skills in drawing. Students practice, sketch, and manipulate the structural elements of art to improve mark making and/or the organizational principles of design in a composition from observation, research, and/or imagination. Through the critique process, students evaluate and respond to their own work and that of their peers. This course incorporates hands-on activities and consumption of art materials.

Link to CPALMS: <http://www.cpalms.org/Public/PreviewCourse/Preview/4696>

Course Number: 0104350

Course Title: Drawing 2

Credit: 1.0

Graduation Requirement: Performing Fine Art

Description: Students develop and refine technical skills and create 2-D compositions with a variety of media in drawing. Student artists sketch, manipulate, and refine the structural elements of art to improve mark-making and/or the organizational principles of design in a composition from observation, research, and/or imagination. Through the critique process, students evaluate and respond to their own work and that of their peers. This course incorporates hands-on activities and consumption of art materials.

Link to CPALMS: <http://www.cpalms.org/Public/PreviewCourse/Preview/972>

Course Number: 1302500

Course Title: Jazz Ens. 1

Credit: 1.0

Graduation Requirement: Performing Fine Art

Description: Students with experience on an instrument suited for jazz ensemble explore the fundamentals of performance practices, improvisation, and music theory through a diverse repertoire of high-quality jazz literature. Students learn the basics of foundational jazz styles, use chord symbols, develop knowledge of musical structure, and study the history of jazz and its iconic musicians. Public performances may serve as a culmination of specific instructional goals. Students may be required to attend and/or participate in rehearsals and performances outside the school day to support, extend, and assess learning in the classroom. Students in this class may need to obtain (e.g., borrow, rent, purchase) an instrument from an outside source.

Link to CPALMS: <http://www.cpalms.org/Public/PreviewCourse/Preview/1414>

Course Number: 1302510

Course Title: Jazz Ens. 2

Credit: 1.0

Graduation Requirement: Performing Fine Art

Description: Students with jazz experience become conversant with basic chord progressions and the scale/chord relationship, strengthen aural skills, and learn to improvise and compose melodies over progressions as they rehearse, perform, and study high-quality jazz ensemble literature. Musicians study jazz history and become familiar with the cultural context of various compositions and artists. Public performances may serve as a culmination of specific instructional goals. Students may be required to attend and/or participate in rehearsals and performances outside the school day to support, extend, and assess learning in the classroom. Students in this class may need to obtain (e.g., borrow, rent, purchase) an instrument from an outside source.

Link to CPALMS: <http://www.cpalms.org/Public/PreviewCourse/Preview/13871>

Course Number: 1006300

Course Title: Journalism 1

Credit: 1.0

Graduation Requirement: Practical Art

Description: The purpose of this course is to enable students to develop fundamental skills in the production of journalism across print, multimedia, web, and broadcast/radio platforms and to develop knowledge of journalism history, ethics use, and management techniques related to the production of journalistic media.

Link to CPALMS: <http://www.cpalms.org/Public/PreviewCourse/Preview/1625>

Course Number: 1006310

Course Title: Journalism 2

Credit: 1.0

Graduation Requirement: Practical Art

Description: The purpose of this course is to enable students to extend fundamental skills in the production of journalism across print, multimedia, web, and broadcast/radio platforms and to develop further knowledge of journalism history, ethics use, and management techniques related to the production of journalistic media.

Link to CPALMS: <http://www.cpalms.org/Public/PreviewCourse/Preview/1626>

Course Number: 1006320

Course Title: Journalism 3

Credit: 1.0

Graduation Requirement: Practical Art

Description: The purpose of this course is to enable students to continue development of fundamental skills in the production of journalism across print, multimedia, web, and broadcast/radio platforms and to develop knowledge of journalism history, ethics use, and management techniques related to the production of journalistic media.

Link to CPALMS: <http://www.cpalms.org/Public/PreviewCourse/Preview/1627>

Course Number: 1006330

Course Title: Journalism 4 Hon

Credit: 1.0

Graduation Requirement: Practical Art

Description: The purpose of this course is to enable students to further extend skills in the production of journalism across print, multimedia, web, and broadcast/radio platforms and to develop further knowledge of journalism history, ethics use, and management techniques related to the production of journalistic media.

Link to CPALMS: <http://www.cpalms.org/Public/PreviewCourse/Preview/1628>

Course Number: 1006331

Course Title: Journalism 5 Hon

Credit: 1.0

Graduation Requirement: Practical Art

Description: The purpose of this course is to perform advanced skills in the production of journalism across print, multimedia, web, and broadcast/radio platforms and to develop advanced knowledge of journalism history, ethics use, and management techniques related to the production of journalistic media.

Link to CPALMS: <http://www.cpalms.org/Public/PreviewCourse/Preview/1629>

Course Number: 1006332

Course Title: Journalism 6 Hon

Credit: 1.0

Graduation Requirement: Practical Art

Description: The purpose of this course is to enable students to perform advanced work in the production of journalism across print, multimedia, web, and broadcast/radio platforms and to develop advanced knowledge of journalism history, ethics use, and management techniques related to the production of journalistic media. School and professional publication efforts are expected.

Link to CPALMS: <http://www.cpalms.org/Public/PreviewCourse/Preview/1630>

Course Number: 1006333

Course Title: Journalism 7 Hon

Credit: 1.0

Graduation Requirement: Practical Art

Description: The purpose of this course is to enable students to perform advanced work in the production of journalism across print, multimedia, web, and broadcast/radio platforms and to develop extended knowledge of journalism history, ethics use, and management techniques related to the production of journalistic media. School and professional publication efforts are expected.

Link to CPALMS: <http://www.cpalms.org/Public/PreviewCourse/Preview/1631>

Course Number: 1006334

Course Title: Journalism 8 Hon

Credit: 1.0

Graduation Requirement: Practical Art

Description: The purpose of this course is to enable students to perform highly advanced work in the production of journalism across print, multimedia, web, and broadcast/radio platforms and to develop extended knowledge of journalism history, ethics use, and management techniques related to the production of journalistic media. School, community, and professional publication is expected.

Link to CPALMS: <http://www.cpalms.org/Public/PreviewCourse/Preview/1632>

Course Number: 1305400

Course Title: Music Ens. 1

Credit: 1.0

Graduation Requirement: Performing Fine Art

Description: Students with little or no experience in a vocal or instrumental ensemble develop basic musicianship and ensemble performance skills through the study of basic, high-quality music in diverse styles. Student musicians focus on building foundational music techniques, music literacy, listening skills, and aesthetic awareness. Public performances may serve as a culmination of specific instructional goals. Students may be required to attend and/or participate in rehearsals and performances outside the school day to support, extend, and assess learning in the classroom. This course, if used for an instrumental ensemble, may also require students to obtain a musical instrument (e.g., borrow, rent, purchase) from an outside source.

Link to CPALMS: <http://www.cpalms.org/Public/PreviewCourse/Preview/3315>

Course Number: 1304300

Course Title: Music Tech & Sound Engineering

Credit: 1.0

Graduation Requirement: Performing Fine Art

Description: Students explore the fundamental applications and tools of music technology and sound engineering. As they create and learn its terminology, students also learn the history and aesthetic development of technology used to capture, create, and distribute music. Public performances may serve as a resource for specific instructional goals. Students may be required to attend one or more performances outside the school day to support, extend, and assess learning in the classroom.

Link to CPALMS: <http://www.cpalms.org/Public/PreviewCourse/Preview/4031>

Course Number: 1300340

Course Title: Music World

Credit: 1.0

Graduation Requirement: Performing Fine Art

Description: Students explore the musical traditions of 20th- and 21st-century American and global communities around the world through study of current trends, focusing on the function of music within various cultures (e.g., jazz, world drumming, mariachi, soul, gamelan, Bollywood, digital). Students examine and report on human activities involving music, technology- and culture-related influences on music, and the sounds and structures of music composition. Public performances may serve as a resource for specific instructional goals. Students may be required to attend one or more performances outside the school day to support, extend, and assess learning in the classroom.

Link to CPALMS: <http://www.cpalms.org/Public/PreviewCourse/Preview/3821>

Course Number: 1007300

Course Title: Speech 1

Credit: 1

Graduation Requirement: Performing Fine Art

Description: This course is designed to build student facility in structuring various types of speeches, researching information, audience analysis, presentation of speeches and building self confidence in public speaking situations. Students will critique speeches, paying attention to content, organization, language, and delivery style, and produce and present well-structured, developed speeches.

Link to CPALMS: <http://www.cpalms.org/Public/PreviewCourse/Preview/1637>

Course Number: 0400310

Course Title: Theatre 1

Credit: 1.0

Graduation Requirement: Performing Fine Art

Description: This course is designed for students with little or no theatre experience, and promotes enjoyment and appreciation for all aspects of theatre. Classwork focuses on the exploration of theatre literature, performance, historical and cultural connections, and technical requirements. Improvisation, creative dramatics, and beginning scene work are used to introduce students to acting and character development. Incorporation of other art forms in theatre also helps students gain appreciation for other art forms, such as music, dance, and visual art.

Link to CPALMS: <http://www.cpalms.org/Public/PreviewCourse/Preview/1089>

Course Number: 0400320

Course Title: Theatre 2

Credit: 1.0

Graduation Requirement: Performing Fine Art

Description: This course is designed for students with a year of experience or more, and promotes enjoyment and appreciation for all aspects of theatre through opportunities to build significantly on existing skills. Classwork focuses on characterization, playwriting, and playwrights' contributions to theatre; while improvisation, creative dramatics, and scene work are used to help students challenge and strengthen their acting skills and explore the technical aspect of scene work.

Link to CPALMS: <http://www.cpalms.org/Public/PreviewCourse/Preview/3983>

Course Number: 0400330

Course Title: Theatre 3 Hon.

Credit: 1.0

Graduation Requirement: Performing Fine Art

Description: This course is designed for students with significant experience in theatre, and promotes depth of engagement and lifelong appreciation for theatre through a broad spectrum of teacher-assigned and self-directed study and performance. Students regularly reflect on aesthetics and issues related to and addressed through theatre, and create within various aspects of theatre in ways that are progressively more innovative. In keeping with the rigor expected in an accelerated setting, students assemble a portfolio that showcases a significant body of work representing personal vision and artistic growth over time; mastery of theatre skills and techniques in one or more areas; and evidence of significant oral and written analytical and problem-solving skills based on their structural, historical, and cultural knowledge.

Link to CPALMS: <http://www.cpalms.org/Public/PreviewCourse/Preview/1091>

Course Number: 0400340

Course Title: Theatre 4 Hon.

Credit: 1.0

Graduation Requirement: Performing Fine Art

Description: This course is designed for students with extensive experience in theatre, and promotes significant depth of engagement and lifelong appreciation for theatre through a broad spectrum of primarily self-directed study and performance. In keeping with the rigor expected in an accelerated setting, students assemble a portfolio that showcases a significant body of work representing personal vision and artistic growth over time; mastery of theatre skills and techniques in one or more areas; and evidence of sophisticated oral and written analytical and problem-solving skills based on their structural, historical, and cultural knowledge.

Link to CPALMS: <http://www.cpalms.org/Public/PreviewCourse/Preview/1092>

Electives

Course Number: 0200320

Course Title: AP Computer Science A

Credit: 1.0

Graduation Requirement: Elective

Description: This course description has been provided by the College Board at the link below:

<https://apcentral.collegeboard.org/courses/ap-computer-science-a>

Course Number: 0200320

Course Title: AP Computer Science Principles

Credit: 1.0

Graduation Requirement: Elective

Description: This course description has been provided by the College Board at the link below:

<https://apcentral.collegeboard.org/courses/ap-computer-science-principles/course>

Course Number: 0200320

Course Title: AP Human Geography

Credit: 1.0

Graduation Requirement: Elective

Description: This course description has been provided by the College Board at the link below:

<https://apcentral.collegeboard.org/courses/ap-human-geography>

Course Number: 0200320

Course Title: AP Psychology

Credit: 1.0

Graduation Requirement: Elective

Description: This course description has been provided by the College Board at the link below:

<https://apcentral.collegeboard.org/courses/ap-psychology>

Course Number: 1700390

Course Title: AVID 1

Credit: 1.0

Graduation Requirement: Elective

Description: AVID (Advancement Via Individual Determination) is offered as a rigorous academic elective course that prepares students for success in four-year colleges. The AVID course is scheduled during the regular school day as a year-long course. Each week students receive instruction utilizing a rigorous college preparatory curriculum provided by AVID Center, tutor-facilitated study groups, motivational activities and academic survival skills. There is an emphasis on analytical writing, preparation for college entrance and placement exams, study skills and test taking, note-taking, and research. In AVID, students participate in activities that incorporate strategies focused on writing, inquiry, collaboration, and reading to support their academic growth.

Link to CPALMS: <http://www.cpalms.org/Public/PreviewCourse/Preview/13909>

Course Number: 1700400

Course Title: AVID 2

Credit: 1.0

Graduation Requirement: Elective

Description: Students in the tenth grade AVID Elective course will refine the AVID strategies to meet their independent needs and learning styles. Students will continue to refine and adjust their academic learning plans and goals, increasing awareness of their actions and behaviors. As students increase the rigorous course load and school/community involvement, they will refine their time management and study skills accordingly. Students will expand their writing portfolio to include: analyzing prompts, supporting arguments and claims, character analysis and detailed reflections. Students will also analyze various documents, in order to participate in collaborative discussions and develop leadership skills in those settings. Students will expand their vocabulary use,

continuing to prepare for college entrance exams and preparation. Text analysis will focus on specific strategies to understand complex texts. Lastly, students will narrow down their college and careers of interest, based on personal interests and goals.

Link to CPALMS: <http://www.cpalms.org/Public/PreviewCourse/Preview/1461>

Course Number: 1700410

Course Title: AVID 3

Credit: 1.0

Graduation Requirement: Elective

Description: AVID (Advancement Via Individual Determination) elective courses at all grade levels are designed to prepare students for success in four-year colleges and universities. The courses emphasize rhetorical reading, analytical writing, collaborative discussion strategies, tutorial inquiry study groups, preparation for college entrance and placement exams, college study skills and test taking strategies, note taking and research. The eleventh grade AVID Elective course is the first part in a junior/senior seminar course that focuses on writing and critical thinking expected of first- and second-year college students. This course is organized around the theme of “Leadership as a Catalyst for Change in Society.” Students study, in depth, exceptional leaders in contemporary society and examine the effect these individuals have had on culture, politics, education, history, science and the arts. The course requires that students read essays, speeches, articles and letters by these leaders, as well as at least one full-length work by the leader or about the leader. Also, each student is required to conduct a research project that is presented in the senior year. In addition to the academic focus of the AVID seminar, there are college-bound activities, methodologies and tasks that should be undertaken during the junior year to support students as they apply to four-year universities and confirm their postsecondary plans.

Link to CPALMS: <http://www.cpalms.org/Public/PreviewCourse/Preview/1462>

Course Number: 1700420

Course Title: AVID 4

Credit: 1.0

Graduation Requirement: Elective

Description: AVID (Advancement Via Individual Determination) elective courses at all grade levels are designed to prepare students for success in four-year colleges and universities. The courses emphasize rhetorical reading, analytical writing, collaborative discussion strategies, tutorial inquiry study groups, preparation for college entrance and placement exams, college study skills and test taking strategies, note taking and research. All AVID seniors are required to develop and present a portfolio representing their years of work in the AVID program as well as complete the requirements for the Seminar course. The AVID Elective twelfth grade course is the second part in a junior/senior seminar course that focuses on writing and critical thinking expected of first- and second-year college students. This course continues around the theme of “Leadership as a Catalyst for Change in Society.” Students will complete a final research essay project from research conducted in their junior year in AVID. In addition to the academic focus of the AVID senior seminar, there are college-bound activities, methodologies and tasks that should be achieved during the senior year that support students as they apply to four- year universities and confirm their postsecondary plans. All AVID seniors are required to develop and present a portfolio representing their years of work in the AVID program, as well as complete the requirements for the seminar course.

Link to CPALMS: <http://www.cpalms.org/Public/PreviewCourse/Preview/1463>

Course Number: 1206320

Course Title: Foundational Skills in Mathematics 9-12

Credit: 1

Graduation Requirement: Elective

Description: This course supports students who need additional instruction in foundational mathematics skills as it relates to core instruction. Instruction will use explicit, systematic, and sequential approaches to mathematics instruction addressing all strands including number sense & operations, algebraic reasoning, functions, geometric reasoning and data analysis & probability. Teachers will use the listed benchmarks that correspond to each students’ needs.

Link to CPALMS: <http://www.cpalms.org/Public/PreviewCourse/Preview/14>

Course Number: 1000412, 1000414, 1000416, 1000418

Course Title: Intensive Reading 1,2,3, and 4

Credit: 1

Graduation Requirement: Elective

Description: The purpose of this course is to provide instruction that enables students to accelerate the development of reading and writing skills and to strengthen those skills so they are able to successfully read and write grade level text independently. Instruction emphasizes reading comprehension, writing fluency, and vocabulary study through the use of a variety of literary and informational texts encompassing a broad range of text structures, genres, and levels of complexity. Texts used for instruction focus on a wide range of topics, including content-area information, in order to support students in meeting the knowledge demands of

increasingly complex text. Students enrolled in the course will engage in interactive text-based discussion, question generation, and research opportunities. They will write in response to reading and cite evidence when answering text dependent questions orally and in writing. The course provides extensive opportunities for students to collaborate with their peers. Scaffolding is provided as necessary as students engage in reading and writing increasingly complex text and is removed as the reading and writing abilities of students improve over time.

Link to CPALMS: <http://www.cpalms.org/Public/PreviewCourse/Preview/1577>

Course Number: 1206320

Course Title: Foundational Skills in Mathematics 9-12

Credit: 1

Graduation Requirement: Elective

Description: This course supports students who need additional instruction in foundational mathematics skills as it relates to core instruction. Instruction will use explicit, systematic, and sequential approaches to mathematics instruction addressing all strands including number sense & operations, algebraic reasoning, functions, geometric reasoning and data analysis & probability. Teachers will use the listed benchmarks that correspond to each students' needs.

Link to CPALMS: <http://www.cpalms.org/Public/PreviewCourse/Preview/14>

Course Number: 0500500, 0500510, 0500520, and 0500530

Course Title: Personal, Career, and School Development Skills 1,2,3, and 4

Credit: 1

Graduation Requirement: Elective

Description: The purpose of this course is to provide students with an opportunity to experience success in school and improve attitudes and behaviors towards learning, self, school and community.

Link to CPALMS: <https://www.cpalms.org/PreviewCourse/Preview/1169>

Course Title: Philosophy

Credit: .5

Graduation Requirement: Elective

Description: The grade 9-12 Philosophy course consists of the following content area strands: American History, World History, Geography, Humanities, Civics and Government. The primary content emphasis for this course pertains to the study of the fundamental questions pertinent to all areas of human activity and inquiries. Content should include, but is not limited to, an introduction to classical and modern philosophies, the fundamental principles of philosophical thought, such as semantics, logic, inductive and deductive reasoning, and social, political and religious philosophies.

Link to CPALMS: <http://www.cpalms.org/Public/PreviewCourse/Preview/628>

Course Number: 2107300

Course Title: Psychology

Credit: .5

Graduation Requirement: Elective

Description: Through the study of psychology, students acquire an understanding of and an appreciation for human behavior, behavior interaction and the progressive development of individuals. The content examined in this first introductory course includes major theories and orientations of psychology, psychological methodology, memory and cognition, human growth and development, personality, abnormal behavior, psychological therapies, stress/coping strategies, and mental health.

Link to CPALMS: <http://www.cpalms.org/Public/PreviewCourse/Preview/655>

Course Number: 1700300

Course Title: Research 1

Credit: 1.0

Graduation Requirement: Elective

Description: The purpose of this course is to enable students to develop fundamental knowledge of the steps in the research process.

Link to CPALMS: <http://www.cpalms.org/Public/PreviewCourse/Preview/1449>

Course Number: 1004300

Course Title: Semantics and Logic Hon.

Credit: .5

Graduation Requirement: Elective

Description: The purpose of this course is to provide students knowledge of the principles of semantics and logic using texts of high complexity and advanced integrated language arts study.

Link to CPALMS: <http://www.cpalms.org/Public/PreviewCourse/Preview/1606>

Course Number: SLS1103

Course Title: Strategies for Success in College, Career, and Life

Credit: .5

Graduation Requirement: Elective

Description: This survey course is designed to assist students in developing skills that will help them succeed in college, career and life. This course will emphasize how basic academic success skills can be applied in a knowledge-based economy. Included in this course are problem solving, communication skills, work ethics, introduction to information literacy and other related topics.

Link to FSCJ: https://floridastatecollegecatalog.fscj.edu/preview_course_nopop.php?catoid=25&coid=52300

Course Number: 2100470

Course Title: Vision/Pursuits Hon

Credit: 1

Graduation Requirement: Elective

Description: The grade 9-12 Visions and Their Pursuits course consists of the following content area strands: World History, American History, Civics and Government, Geography, and Humanities. The primary content emphasis for this course pertains to the chronological study of the United States during the period of European exploration through World War I and the collective vision of historical time periods. Content will include, but is not limited to, the foundation and early development of the United States as organized by the visions of those who participated in the revolutions leading to the establishment and early success of the United States, the political, social, cultural, intellectual, and technological revolutions of the United States, the structure and function of political divisions, the organization of the federal government as outlined in the U.S. Constitution, the impact of economic, social, and political changes on traditional American values, reactions to changes, and growth of sectionalism, the failure of previous visions, and the emergence of an industrial, urban and pluralistic society that demands new visions to carry the nation forward.

Link to CPALMS: <http://www.cpalms.org/Public/PreviewCourse/Preview/602>

Course Number: 2100380

Course Title: Visions and Their Pursuits

Credit: 1

Graduation Requirement: Elective

Description: **Visions and Their Pursuits: An American Tradition-U.S. History to 1920** - The grade 9-12 Visions and Their Pursuits course consists of the following content area strands: World History, American History, Civics and Government, Geography, and Humanities. The primary content emphasis for this course pertains to the chronological study of the United States during the period of European exploration through World War I and the collective vision of historical time periods. Content will include, but is not limited to, the foundation and early development of the United States as organized by the visions of those who participated in the revolutions leading to the establishment and early success of the United States, the political, social, cultural, intellectual, and technological revolutions of the United States, the structure and function of political divisions, the organization of the federal government as outlined in the U.S. Constitution, the impact of economic, social, and political changes on traditional American values, reactions to changes, and growth of sectionalism, the failure of previous visions, and the emergence of an industrial, urban and pluralistic society that demands new visions to carry the nation forward.

Link to CPALMS: <http://www.cpalms.org/Public/PreviewCourse/Preview/596>

Course Number: 2105310

Course Title: World Religions

Credit: .5

Graduation Requirement: Elective

Description: The grade 9-12 World Religions course consists of the following content area strands: World History, Geography and Humanities. The primary content emphasis for this course pertains to the study of major world religious traditions of Buddhism, Christianity, Confucianism, Hinduism, Islam, Judaism, Shintoism and Taoism. Students will identify criteria upon which religious beliefs are based, analyze relationships between religious and social and political institutions, trace the major developments of the world's living religions, distinguish the similarities and differences among the world's major religious traditions, synthesize

information and ideas from conflicting religious beliefs, and interpret the development of a society as reflected by its religious beliefs.

Link to CPALMS: <http://www.cpalms.org/Public/PreviewCourse/Preview/627>

Course Number: 1009300

Course Title: Writing 1

Credit: 1

Graduation Requirement: Elective

Description: The purpose of this course is to enable students, using texts of appropriate complexity, to develop knowledge of world literature through integrated educational experiences of reading, writing, speaking and listening, and language. Emphasis will be on representative world literature, with its varied cultural influences, highlighting the major genres, themes, issues, and influences associated with the selections.

Link to CPALMS: <http://www.cpalms.org/Public/PreviewCourse/Preview/1652>

Course Number: 1009310

Course Title: Writing 2

Credit: 1

Graduation Requirement: Elective

Description: The purpose of this course is to enable students to develop and use grade level 11-12 writing and language skills in a variety of writing formats for argumentative, informative, and narrative purposes to ensure preparation for college and career readiness.

Link to CPALMS: <http://www.cpalms.org/Public/PreviewCourse/Preview/1653>

English

Course Number: 1001430

Course Title: ADV PL English Language and Composition

Credit: 1

Graduation Requirement: English

Description: This course description has been provided by the College Board at the link below:

<https://apcentral.collegeboard.org/courses/ap-english-language-and-composition>

Course Number: 1001430

Course Title: ADV PL English Literature and Composition

Credit: 1

Graduation Requirement: English

Description: This course description has been provided by the College Board at the link below:

<https://apcentral.collegeboard.org/courses/ap-english-literature-and-composition>

Course Number: 1001310

Course Title: English 1

Credit: 1

Graduation Requirement: English

Description: The purpose of this course is to provide English 1 students, using texts of high complexity, integrated language arts study in reading, writing, speaking, listening, and language for college and career preparation and readiness.

Link to CPALMS: <http://www.cpalms.org/Public/PreviewCourse/Preview/1674>

Course Number: 1001320

Course Title: English 1 Hon.

Credit: 1

Graduation Requirement: English

Description: The purpose of this course is to provide grade 9 students, using texts of high complexity, advanced integrated language arts study in reading, writing, speaking, listening, and language for college and career preparation and readiness.

Honors and Advanced Level Course Note: Academic rigor is more than simply assigning to students a greater quantity of work. Through the application, analysis, evaluation, and creation of complex ideas that are often abstract and multi-faceted, students are challenged to think and collaborate critically on the content they are learning.

Link to CPALMS: <http://www.cpalms.org/Public/PreviewCourse/Preview/1581>

Course Number: 1001340

Course Title: English 2

Credit: 1

Graduation Requirement: English

Description: The purpose of this course is to provide grade 10 students, using texts of high complexity, integrated language arts study in reading, writing, speaking, listening, and language for college and career preparation and readiness.

Link to CPALMS: <http://www.cpalms.org/Public/PreviewCourse/Preview/1675>

Course Number: 1001350

Course Title: English 2 Hon.

Credit: 1

Graduation Requirement: English

Description: The purpose of this course is to provide grade 10 students, using texts of high complexity, advanced integrated language arts study in reading, writing, speaking, listening, and language in preparation for college and career readiness.

Honors and Advanced Level Course Note: Academic rigor is more than simply assigning to students a greater quantity of work.

Through the application, analysis, evaluation, and creation of complex ideas that are often abstract and multi-faceted, students are challenged to think and collaborate critically on the content they are learning.

Link to CPALMS: <https://www.cpalms.org/PreviewCourse/Preview/1583>

Course Number: 1001370

Course Title: English 3

Credit: 1

Graduation Requirement: English

Description: The purpose of this course is to provide grade 11 students, using texts of high complexity, integrated language arts study in reading, writing, speaking, listening, and language for college and career preparation and readiness.

Link to CPALMS: <http://www.cpalms.org/Public/PreviewCourse/Preview/1676>

Course Number: 1001405

Course Title: English 4: FL College Prep.

Credit: 1

Graduation Requirement: English

Description: This course incorporates reading and writing study through writing a variety of informative texts using grade-level writing craft and through the in-depth reading and analysis of informational selections in order to develop critical reading and writing skills necessary for success in college courses. This course prepares students for successful completion of Florida college English courses. The benchmarks reflect the Florida Postsecondary Readiness Competencies necessary for entry-level college courses.

Link to CPALMS: <http://www.cpalms.org/Public/PreviewCourse/Preview/1775>

Course Number: ENC1101

Course Title: English Composition 1

Credit: 1

Graduation Requirement: English

Description: This course embodies the fundamentals of effective expression with emphasis on the various forms of expository writing, logical and imaginative thinking, and reading for understanding. The course provides instruction in sentence structure, diction, organization of short essays, correct usage of standard American English documentation skills, and writing with sources. This course includes reading and writing competencies. (CBE)

Link to FSCJ: https://floridastatecollegecatalog.fscj.edu/preview_course_nopop.php?catoid=25&coid=52300

Course Number: LIT2000

Course Title: Introduction to Literature

Credit: 1

Graduation Requirement: English

Description: Prerequisite: ENC 1101 with a grade of "C" or better. This course emphasizes reading selections for understanding, appreciation and written analysis of selected works. The course considers the major literary forms and their distinctive characteristics and conventions, principle literary themes and different critical approaches. The purpose of the course is to increase personal satisfaction in literature and to prepare students for further literary study. This course includes reading, speaking and writing competencies. Three contact hours. (CBE) A.A.

Link to FSCJ: http://marketing.fscj.edu/catalogs/2001_2002/Courses/credit/LIT/LIT2000.html

Course Number: ENC1102

Course Title: Writing about Non Fiction

Credit: 1

Graduation Requirement: English

Description: This course focuses on studying non-fiction writing in its many forms. The student will develop a proficiency in evaluating texts and writing analytically about these texts. This course provides a solid introduction to research writing as well as the CLAST writing skills. This course meets the Gordon Rule writing requirement. (CBE)

Link to FSCJ: https://www.fscj.edu/catalogs/2001_2002/Courses/credit/ENC/ENC1102.html

Foreign Language

Course Number: 0701320

Course Title: French 1

Credit: 1

Graduation Requirement: Foreign Language

Description: French 1 introduces students to the target language and its culture. The student will develop communicative skills in all 3 modes of communication and cross-cultural understanding. Emphasis is placed on proficient communication in the language. An introduction to reading and writing is also included as well as culture, connections, comparisons, and communities.

Link to CPALMS: <http://www.cpalms.org/Public/PreviewCourse/Preview/1205>

Course Number: 0701330

Course Title: French 2

Credit: 1

Graduation Requirement: Foreign Language

Description: French 2 reinforces the fundamental skills acquired by the students in French 1. The course develops increased listening, speaking, reading, and writing skills as well as cultural awareness. Specific content to be covered is a continuation of listening and oral skills acquired in French 1. Reading and writing receive more emphasis, while oral communication remains the primary objective. The cultural survey of the target language-speaking people is continued.

Link to CPALMS: <https://www.cpalms.org/PreviewCourse/Preview/1206>

Course Number: 0701340

Course Title: French 3 Honors

Credit: 1

Graduation Requirement: Foreign Language

Description: French 3 provides mastery and expansion of skills acquired by the students in French 2. Specific content includes, but is not limited to, expansions of vocabulary and conversational skills through discussions of selected readings. Contemporary vocabulary stresses activities which are important to the everyday life of the target language-speaking people.

Link to CPALMS: <http://www.cpalms.org/Public/PreviewCourse/Preview/1207>

Course Number: 0701350

Course Title: French 4

Credit: 1

Graduation Requirement: Foreign Language

Description: French 4 expands the skills acquired by the students in French 3. Specific content includes, but is not limited to, more advanced language structures and idiomatic expressions, with emphasis on conversational skills. There is additional growth in vocabulary for practical purposes, including writing. Reading selections are varied and taken from the target language newspapers, magazines, and literary works.

Link to CPALMS: <https://www.cpalms.org/PreviewCourse/Preview/1208>

Course Number: 0701340

Course Title: Spanish 1

Credit: 1

Graduation Requirement: Foreign Language

Description: Spanish 1 introduces students to the target language and its culture. The student will develop communicative skills in all 3 modes of communication and cross-cultural understanding. Emphasis is placed on proficient communication in the language. An introduction to reading and writing is also included as well as culture, connections, comparisons, and communities.

Link to CPALMS: <http://www.cpalms.org/Public/PreviewCourse/Preview/1285>

Course Number: 0701350

Course Title: Spanish 2

Credit: 1

Graduation Requirement: Foreign Language

Description: Spanish 2 reinforces the fundamental skills acquired by the students in Spanish 1. The course develops increased listening, speaking, reading, and writing skills as well as cultural awareness. Specific content to be covered is a continuation of listening and oral skills acquired in Spanish 1. Reading and writing receive more emphasis, while oral communication remains the primary objective. The cultural survey of the target language-speaking people is continued.

Link to CPALMS: <http://www.cpalms.org/Public/PreviewCourse/Preview/1286>

Course Number: 0701360

Course Title: Spanish 3 Honors

Credit: 1

Graduation Requirement: Foreign Language

Description: Spanish 3 provides mastery and expansion of skills acquired by the students in Spanish 2. Specific content includes, but is not limited to, expansions of vocabulary and conversational skills through discussions of selected readings. Contemporary vocabulary stresses activities which are important to the everyday life of the target language-speaking people.

Link to CPALMS: <http://www.cpalms.org/Public/PreviewCourse/Preview/13819>

Course Number: 0701370

Course Title: Spanish 4 Honors

Credit: 1

Graduation Requirement: Foreign Language

Description: Spanish 4 expands the skills acquired by the students in Spanish 3. Specific content includes, but is not limited to, more advanced language structures and idiomatic expressions, with emphasis on conversational skills. There is additional growth in vocabulary for practical purposes, including writing. Reading selections are varied and taken from the target language newspapers, magazines, and literary works.

Link to CPALMS: <http://www.cpalms.org/Public/PreviewCourse/Preview/1288>

Mathematics

Course Number: 1200310

Course Title: Algebra 1

Credit: 1

Graduation Requirement: Algebra

Description: In Algebra 1, instructional time will emphasize five areas: (1) performing operations with polynomials and radicals, and extending the Laws of Exponents to include rational exponents; (2) extending understanding of functions to linear, quadratic and exponential functions and using them to model and analyze real-world relationships; (3) solving quadratic equations in one variable and systems of linear equations and inequalities in two variables; (4) building functions, identifying their key features and representing them in various ways and (5) representing and interpreting categorical and numerical data with one and two variables.

Link to CPALMS: <https://www.cpalms.org/PreviewCourse/Preview/1>

Course Number: 1200320

Course Title: Algebra 1 Honors

Credit: 1

Graduation Requirement: Algebra

Description: In Algebra 1 Honors, instructional time will emphasize five areas: (1) performing operations with polynomials and radicals, and extending the Laws of Exponents to include rational exponents; (2) extending understanding of functions to linear, quadratic and exponential functions and using them to model and analyze real-world relationships; (3) solving quadratic equations in one variable and systems of linear equations and inequalities in two variables; (4) building functions, identifying their key features and representing them in various ways and (5) representing and interpreting categorical and numerical data with one and two variables.

Link to CPALMS: <https://www.cpalms.org/PreviewCourse/Preview/13011>

Course Number: 1200330

Course Title: Algebra 2

Credit: 1

Graduation Requirement: Mathematics

Description: In Algebra 2, instructional time will emphasize five areas: (1) extending arithmetic operations with algebraic expressions to include radical and rational expressions and polynomial division; (2) graphing and analyzing functions including polynomials, absolute value, radical, rational, exponential and logarithmic; (3) building functions using compositions, inverses and transformations; (4) extending systems of equations and inequalities to include non-linear expressions and (5) developing understanding of the complex number system, including complex numbers as roots of polynomial equations.

Link to CPALMS: <https://www.cpalms.org/PreviewCourse/Preview/13012>

Course Number: 1200340

Course Title: Algebra 2 Honors

Credit: 1

Graduation Requirement: Mathematics

Description: In Algebra 2 Honors, instructional time will emphasize six areas: (1) developing understanding of the complex number system, including complex numbers as roots of polynomial equations; (2) extending arithmetic operations with algebraic expressions to include polynomial division, radical and rational expressions; (3) graphing and analyzing functions including polynomials, absolute value, radical, rational, exponential and logarithmic; (4) extending systems of equations and inequalities to include non-linear expressions; (5) building functions using compositions, inverses and transformations and (6) developing understanding of probability concepts.

Link to CPALMS: <https://www.cpalms.org/PreviewCourse/Preview/13013>

Course Number: MAC1105

Course Title: College Algebra

Credit: 1

Graduation Requirement: Mathematics

Description: The major topics included in this course are linear equations and inequalities; quadratic equations and inequalities; relations and functions; graphs; systems of equations and inequalities; exponential and logarithmic functions; and applications. A review of algebraic techniques is also included in this course as well as a review of polynomials, factoring, exponents, roots and radicals. (CBE)

Link to FSCJ: https://www.fscj.edu/catalogs/2001_2002/Courses/credit/MAC/MAC1105.html

Course Number: 1206310

Course Title: Geometry

Credit: 1

Graduation Requirement: Geometry

Description: In Geometry, instructional time will emphasize five areas: (1) proving and applying relationships and theorems involving two-dimensional figures using Euclidean geometry and coordinate geometry; (2) establishing congruence and similarity using criteria from Euclidean geometry and using rigid transformations; (3) extending knowledge of geometric measurement to two-dimensional figures and three-dimensional figures; (4) creating and applying equations of circles in the coordinate plane and (5) developing an understanding of right triangle trigonometry.

Link to CPALMS: <https://www.cpalms.org/PreviewCourse/Preview/13029>

Course Number: 1206320

Course Title: Geometry Honors

Credit: 1

Graduation Requirement: Geometry

Description: In Geometry Honors, instructional time will emphasize five areas: (1) proving and applying relationships and theorems involving two-dimensional figures using Euclidean geometry and coordinate geometry; (2) establishing congruence and similarity using criteria from Euclidean geometry and using rigid transformations; (3) extending knowledge of geometric measurement to two-dimensional figures and three-dimensional figures; (4) creating and applying equations of circles in the coordinate plane and (5) developing an understanding of right triangle trigonometry.

Link to CPALMS: <https://www.cpalms.org/PreviewCourse/Preview/37>

Course Number: 1200700

Course Title: Math for College Algebra

Credit: 1

Graduation Requirement: Mathematics

Description: In Mathematics for College Algebra, instructional time will emphasize five areas: (1) developing fluency with the Laws of Exponents with numerical and algebraic expressions; (2) extending arithmetic operations with algebraic expressions to include rational and polynomial expressions; (3) solving one-variable exponential, logarithmic, radical and rational equations and interpreting the viability of solutions in real-world contexts; (4) modeling with and applying linear, quadratic, absolute value, exponential, logarithmic and piecewise functions and systems of linear equations and inequalities; (5) extending knowledge of functions to include inverse and composition.

Link to CPALMS: <https://www.cpalms.org/PreviewCourse/Preview/22379>

Course Number: 1207350

Course Title: Mathematics for College Liberal Arts

Credit: 1

Graduation Requirement: Mathematics

Description: In Mathematics for College Liberal Arts, instructional time will emphasize five areas: (1) analyzing and applying linear and exponential functions within a real-world context; (2) utilizing geometric concepts to solve real-world problems; (3) extending understanding of probability theory; (4) representing and interpreting univariate and bivariate data and (5) developing understanding of logic and set theory.

Link to CPALMS: <https://www.cpalms.org/PreviewCourse/Preview/20426>

Course Number: 1200384

Course Title: Mathematics for Data and Financial Literacy

Credit: 1

Graduation Requirement: Mathematics

Description: In Mathematics for Data and Financial Literacy, instructional time will emphasize five areas: (1) extending knowledge of ratios, proportions and functions to data and financial contexts; (2) developing understanding of basic economic and accounting principles; (3) determining advantages and disadvantages of credit accounts and short- and long-term loans; (4) developing understanding of planning for the future through investments, insurance and retirement plans and (5) extending knowledge of data analysis to create and evaluate reports and to make predictions.

Link to CPALMS: <https://www.cpalms.org/PreviewCourse/Preview/22382>

Course Number: 1202340

Course Title: Pre-Calculus Honors

Credit: 1

Graduation Requirement: Mathematics

Description: In Precalculus Honors, instructional time will emphasize six areas: (1) extending right triangle trigonometry to unit circle trigonometry and trigonometric functions; (2) extending understanding of functions to trigonometric; (3) developing understanding of conic sections; (4) representing and performing operations with complex numbers and vectors in the coordinate plane; (5) extending understanding of relations in the plane using parametric representations, including polar coordinates and (6) analyzing arithmetic and geometric sequences and series.

Link to CPALMS: <http://www.cpalms.org/Public/PreviewCourse/Preview/13018>

Physical Education

Course Number: 1503310

Course Title: Basketball

Credit: .5

Graduation Requirement: Physical Education

Description: Basketball provides students with opportunities to acquire knowledge and skills in basketball that may be used in recreational pursuits today, as well as in later life, and maintain their personal fitness. The content includes in-depth knowledge and application of skills, techniques, strategies of team play, rules, and safety practices necessary to participate in basketball, and knowledge of the organization and administration of basketball activities.

Link to CPALMS: <http://www.cpalms.org/Public/PreviewCourse/Preview/4019>

Course Number: 1503315

Course Title: Basketball 2

Credit: .5

Graduation Requirement: Physical Education

Description: The purpose of this course is to provide more in-depth instruction of the fundamental skills, tactics, rules and etiquette in basketball. Introduction to systems of play will be included to enhance the student's understanding. Advanced skills and drills which directly affect student's physical and cognitive abilities will be covered. Students will participate in advanced individual and team techniques in relationship to basketball strategy. Participate in course activities will continue to enhance healthy behaviors that influence students to participate in physical activities throughout their life.

Link to CPALMS: <http://www.cpalms.org/Public/PreviewCourse/Preview/10303>

Course Number: 1501340

Course Title: Beginning Weight Training (Weight Training 1)

Credit: .5

Graduation Requirement: Physical Education

Description: The purpose of this course is to develop the physical skills necessary to be competent in many forms of movement as it relates to weight training. The integration of fitness concepts throughout the content is critical to the success of this course.

Link to CPALMS: <http://www.cpalms.org/Public/PreviewCourse/Preview/235>

Course Number: 1501350

Course Title: Intermediate Weight Training (Weight Training 2)

Credit: .5

Graduation Requirement: Physical Education

Description: The purpose of this course is to develop the physical skills necessary to be competent in many forms of movement as it relates to weight training. The integration of fitness concepts throughout the content is critical to the success of this course.

Link to CPALMS: <http://www.cpalms.org/Public/PreviewCourse/Preview/236>

Course Number: 1501360

Course Title: Advanced Weight Training (Weight Training 3)

Credit: .5

Graduation Requirement: Physical Education

Description: The purpose of this course is to develop the physical skills necessary to be competent in many forms of movement as it relates to weight training. The integration of fitness concepts throughout the content is critical to the success of this course.

Link to CPALMS: <http://www.cpalms.org/Public/PreviewCourse/Preview/237>

Course Number: 1501410

Course Title: Beginning PWR Weight Training (Weight Training 4)

Credit: .5

Graduation Requirement: Physical Education

Description: The purpose of this course is to develop the physical skills necessary to be competent in many forms of movement as it relates to weight training. The integration of fitness concepts throughout the content is critical to the success of this course.

Link to CPALMS: <http://www.cpalms.org/Public/PreviewCourse/Preview/4090>

Course Number: 1502410

Course Title: Individual Dual Sports 1

Credit: .5

Graduation Requirement: Physical Education

Description: The purpose of this course is to enable students to develop knowledge and skills specified in individual and dual sports and to maintain health related fitness.

Link to CPALMS: <http://www.cpalms.org/Public/PreviewCourse/Preview/244>

Course Number: 1502420

Course Title: Individual Dual Sports 2

Credit: .5

Graduation Requirement: Physical Education

Description: The purpose of this course is to enable students to develop knowledge and skills specified in individual and dual sports and to maintain health related fitness.

Link to CPALMS: <http://www.cpalms.org/Public/PreviewCourse/Preview/245>

Course Number: 1502480

Course Title: Outdoor Education

Credit: .5

Graduation Requirement: Physical Education

Description: The purpose of this course is to focus on activities that encourage student movement within the outdoors.

Link to CPALMS: <http://www.cpalms.org/Public/PreviewCourse/Preview/249>

Course Number: 1505430

Course Title: Racquetball 1

Credit: .5

Graduation Requirement: Physical Education

Description: The purpose of this course is to focus on activities that encourage student movement.

Link to CPALMS: <https://www.cpalms.org/Public/PreviewCourse/Preview/269>

Course Number: 1505440

Course Title: Racquetball 2

Credit: .5

Graduation Requirement: Physical Education

Description: The purpose of this course is to focus on activities that encourage student movement.

Link to CPALMS: <https://www.cpalms.org/PreviewCourse/Preview/270>

Course Number: 1502470

Course Title: Recreational Activities

Credit: .5

Graduation Requirement: Physical Education

Description: The purpose of this course is to focus on recreational sports and games with the intention of participating in and developing skills in specific leisure like activities.

Link to CPALMS: <http://www.cpalms.org/Public/PreviewCourse/Preview/245>

<http://www.cpalms.org/Public/PreviewCourse/Preview/248>

Course Number: 1503350

Course Title: Team Sports 1

Credit: .5

Graduation Requirement: Physical Education

Description: The purpose of this course is to develop the physical skills necessary to be competent in many forms of movement, knowledge of team sports concepts such as offensive and defensive strategies and tactics, and appropriate social behaviors within a team or group setting. The integration of fitness concepts throughout the content is critical to the success of this course.

Link to CPALMS: <http://www.cpalms.org/Public/PreviewCourse/Preview/245>
<http://www.cpalms.org/Public/PreviewCourse/Preview/256>

Course Number: 1503360

Course Title: Team Sports 2

Credit: .5

Graduation Requirement: Physical Education

Description: The purpose of this course is to develop the physical skills necessary to be competent in many forms of movement, knowledge of team sports concepts such as offensive and defensive strategies and tactics, and appropriate social behaviors within a team or group setting. The integration of fitness concepts throughout the content is critical to the success of this course.

Link to CPALMS: <http://www.cpalms.org/Public/PreviewCourse/Preview/245>
<http://www.cpalms.org/Public/PreviewCourse/Preview/2567>

Course Number: 1505500

Course Title: Volleyball 1

Credit: .5

Graduation Requirement: Physical Education

Description: An introductory course in the fundamentals of volleyball including passing, serving, setting and spiking. Students will learn rules and court strategy for playing the game. Emphasis will be on total fitness and recreational skills for leisure and lifetime activities.

Link to CPALMS: <http://www.cpalms.org/Public/PreviewCourse/Preview/245>
<http://www.cpalms.org/Public/PreviewCourse/Preview/13467?isShowCurrent=false%27>

Science

Course Number: 2003370

Course Title: AP Chemistry

Credit: 1

Graduation Requirement: Equally Rigorous

Description: The course description is provided by the College board via the link below:

<https://apstudents.collegeboard.org/courses/ap-chemistry>

Course Number: 2001380

Course Title: AP Environment Science

Credit: 1

Graduation Requirement: Equally Rigorous

Description: The course description is provided by the College board via the link below:

<https://apstudents.collegeboard.org/courses/ap-environmental-science>

Course Number: 2000360

Course Title: Anatomy and Physiology Honors

Credit: 1

Graduation Requirement: Equally Rigorous

Description: While the content focus of this course is consistent with the Anatomy and Physiology course, students will explore these concepts in greater depth. In general, the academic pace and rigor will be greatly increased for honors level course work. Laboratory investigations that include the use of scientific inquiry, research, measurement, problem solving, laboratory apparatus and technologies, experimental procedures, and safety procedures are an integral part of this course. The National Science Teachers Association (NSTA) recommends that at the high school level, all students should be in the science lab or field, collecting data every week.

Link to CPALMS: <http://www.cpalms.org/Public/PreviewCourse/Preview/66>

Course Number: 2000310

Course Title: Biology 1

Credit: 1

Graduation Requirement: Biology

Description: Biology I will provide opportunities to students for general exploratory experiences and activities in the fundamental concepts of life. Topics will include, but not be limited to: the scientific method, measurements, laboratory apparatus usage and safety, cell biology and cell reproduction, principles of genetics, biological change through time, classification, microbiology, structure and function of plants and animals, structure and function of the human body, and ecology. Laboratory activities, which include the use of the scientific method, measurement, laboratory apparatus, and safety, are an integral part of this course.

Link to CPALMS: <https://www.cpalms.org/PreviewCourse/Preview/4258>

Course Number: 2000320

Course Title: Biology 1 Honors

Credit: 1

Graduation Requirement: Biology

Description: Biology I Honors will provide opportunities to students for general exploratory experiences and activities in the fundamental concepts of life. Topics will include, but not be limited to: the scientific method, laboratory apparatus usage and safety, biochemistry, cell biology, genetics, botany, zoology, human anatomy and physiology, and ecological relationships. Laboratory activities, which include the use of the scientific method, measurement, laboratory apparatus, and safety, are an integral part of this course.

Link to CPALMS: <http://www.cpalms.org/Public/PreviewCourse/Preview/70>

Course Number: 2003340

Course Title: Chemistry 1

Credit: 1

Graduation Requirement: Equally Rigorous

Description: Chemistry I will provide opportunities for students to study the composition, properties, and changes associated with matter. Topics will include, but not be limited to: classification and structure of matter, atomic theory, the periodic table, bonding, chemical formulas, chemical reactions, balanced equations, behavior of gases, physical changes, acids, bases, and salts. Laboratory activities, which include the use of the scientific method, measurement, laboratory apparatus, and safety, are an integral part of this course.

Link to CPALMS: <http://www.cpalms.org/Public/PreviewCourse/Preview?id=76&backend=true>

Course Number: 2003350

Course Title: Chemistry Honors

Credit: 1

Graduation Requirement: Equally Rigorous

Description: Chemistry 1 Honors will provide students with an opportunity to study the composition properties and changes associate with matter. Topics will include but not be limited to: heat, changes of matter, atomic structure, bonding, the periodic table, formulas, equations, mole concept, gas laws, reactions, solutions, equilibrium systems, and oxidation reduction reactions, laboratory activities which include, the use of the scientific method, measurement, laboratory apparatus, and safety, are an integral part of this course.

Link to CPALMS: <http://www.cpalms.org/Public/PreviewCourse/Preview/77>

Course Number: 2001340

Course Title: Environmental Science

Credit: 1

Graduation Requirement: Equally Rigorous

Description: Environmental Science is designed to show thematic connections between a variety of science disciplines including biology, chemistry, and physics. It gives students a coherent and realistic picture of the applications of a variety of scientific concepts as they manifest in our environment. Students will focus on human population growth, natural resources, and ecosystem dynamics.

Link to CPALMS: <http://www.cpalms.org/Public/PreviewCourse/Preview/82>

Course Number: 2003390

Course Title: Physics 1 Honors

Credit: 1

Graduation Requirement: Equally Rigorous

Description: While the content focus of this course is consistent with the Physics I course, students will explore these concepts in greater depth. In general, the academic pace and rigor will be greatly increased for honors level course work. Laboratory investigations that include the use of scientific inquiry, research, measurement, problem solving, laboratory apparatus and technologies, experimental procedures, and safety procedures are an integral part of this course. The National Science Teachers Association (NSTA) recommends that at the high school level, all students should be in the science lab or field, collecting data every week.

Link to CPALMS: <http://www.cpalms.org/Public/PreviewCourse/Preview/4317>

Course Number: BSC2010

Course Title: Principles of Biology 1

Credit: 1

Graduation Requirement: Biology

Description: This course, an introduction to the principles of biology, includes studies of cellular organization, genetics and evolution. This course fulfills the General Education Requirements and the laboratory requirement needed by many students who plan to transfer to a four-year institution.

Link to FSCJ: https://www.fscj.edu/catalogs/2001_2002/Courses/credit/BSC/BSC2010C.html

Course Number: BSC2011

Course Title: Principles of Biology 2

Credit: 1

Graduation Requirement: Biology

Description: This course is a continuation of Principles of Biology I and recommended for science students transferring to four-year institutions. The course material emphasizes survey of the kingdoms, evolution and selected ecological topics and includes a required laboratory experience to reinforce subject matter.

Link to FSCJ: https://www.fscj.edu/catalogs/2001_2002/Courses/credit/BSC/BSC2011C.html

Course Number: OCB2000

Course Title: Fundamentals of Marine Biology

Credit: 1

Graduation Requirement: Biology

Description: Students will benefit by taking Principles of Biology I and/or high school chemistry, physics or Introduction to General Chemistry prior to enrolling in this course. This course consists of a comprehensive survey of marine ecosystems with emphasis on the local flora and fauna. Laboratory includes collection and identification of marine organisms.

Link to FSCJ: https://www.fscj.edu/catalogs/2007_2008/courses/credit/OCB/OCB2000C.html

Social Studies

Course Number: 2100330

Course Title: Adv PL Macroeconomics

Credit: .5

Graduation Requirement: Economics

Description: This course description has been provided by the College Board at the link below:

<https://apcentral.collegeboard.org/courses/ap-macroeconomics>

Course Number: 2106420

Course Title: Adv PL US Government and Politics

Credit: .5

Graduation Requirement: American Government

Description: This course description has been provided by the College Board at the link below:

<https://apcentral.collegeboard.org/courses/ap-united-states-government-and-politics>

Course Number: 2100330

Course Title: Adv PL U.S. History

Credit: 1

Graduation Requirement: American History

Description: This course description has been provided by the College Board at the link below:

<https://apcentral.collegeboard.org/courses/ap-united-states-history>

Course Number: 2100330

Course Title: Adv PL World History

Credit: 1

Graduation Requirement: World History: Modern

Description: This course description has been provided by the College Board at the link below:

<https://apcentral.collegeboard.org/courses/ap-world-history>

Course Number: 2102335

Course Title: Economics with Financial Literacy

Credit: .5

Graduation Requirement: Economics

Description: The grade 9-12 Economics course consists of the following content area strands: Economics and Geography. The primary content emphasis for this course pertains to the study of the concepts and processes of the national and international economic systems. Content should include, but is not limited to, currency, banking, and monetary policy, the fundamental concepts relevant to the major economic systems, the global market and economy, major economic theories and economists, the role and influence of the government and fiscal policies, economic measurements, tools, and methodology, financial and investment markets, and the business cycle.

Link to CPALMS: <http://www.cpalms.org/Public/PreviewCourse/Preview/13395>

Course Number: 2102345

Course Title: Economics with Financial Literacy Hon

Credit: .5

Graduation Requirement: Economics

Description: The grade 9-12 Economics course consists of the following content area strands: Economics and Geography. The primary content emphasis for this course pertains to the study of the concepts and processes of the national and international economic systems. Content should include, but is not limited to, currency, banking, and monetary policy, the fundamental concepts relevant to the major economic systems, the global market and economy, major economic theories and economists, the role and influence of the government and fiscal policies, economic measurements, tools, and methodology, financial and investment markets, and the business cycle.

Honors/Advanced courses offer scaffolded learning opportunities for students to develop the critical skills of analysis, synthesis, and evaluation in a more rigorous and reflective academic setting. Students are empowered to perform at higher levels as they engage in the following: analyzing historical documents and supplementary readings, working in the context of thematically categorized information, becoming proficient in note-taking, participating in Socratic seminars/discussions, emphasizing free-response and document-based writing, contrasting opposing viewpoints, solving problems, etc. Students will develop and demonstrate their skills through participation in a capstone and/or extended research-based paper/project (e.g., history fair, participatory citizenship project, mock congressional hearing, projects for competitive evaluation, investment portfolio contests, or other teacher-directed projects).

Link to CPALMS: <http://www.cpalms.org/Public/PreviewCourse/Preview/2040>

Course Number: 2102371

Course Title: Personal Finance and Money Management

Credit: .5

Graduation Requirement: Personal Financial Literacy

Description: In Personal Finance and Money Management, instructional time will emphasize seven areas: (1) exploring how personal financial decisions are made, including understanding how cognitive biases impact decision making, (2) understanding how wages and salaries are earned, including the types of taxes owed, and evaluating various post-secondary paths and career options, (3) developing personal or family budgets and exploring how to purchase goods and services by weighing the costs and benefits of those goods and services, (4) analyzing how interest can be earned by saving now, which allows for the purchase of more goods and services later and understanding how to compare various savings accounts and services offered through financial institutions, (5) determining advantages and disadvantages of credit accounts that allow for the borrowing of money to purchase goods and services while paying for them in the future, usually with interest, and short- and long-term loans, (6) developing understanding of planning for the future through investment accounts and retirement plans and comparing investment choices by analyzing rates of return and risk, while analyzing how diversification is one way to reduce investment risk, (7) recognizing that there are risks that can result in lost income, health, or identity and that those risks can be accepted, reduced, or transferred to others through the purchase of insurance.

Link to CPALMS: <https://www.cpalms.org/PreviewCourse/Preview/22612>

Course Number: 2102371

Course Title: Personal Finance and Money Management Honors

Credit: .5

Graduation Requirement: Personal Financial Literacy

Description: In Personal Finance and Money Management, instructional time will emphasize seven areas: (1) exploring how personal financial decisions are made, including understanding how cognitive biases impact decision making, (2) understanding how wages and salaries are earned, including the types of taxes owed, and evaluating various post-secondary paths and career options, (3) developing personal or family budgets and exploring how to purchase goods and services by weighing the costs and benefits of those goods and services, (4) analyzing how interest can be earned by saving now, which allows for the purchase of more goods and services later and understanding how to compare various savings accounts and services offered through financial institutions, (5) determining advantages and disadvantages of credit accounts that allow for the borrowing of money to purchase goods and services while paying for them in the future, usually with interest, and short- and long-term loans, (6) developing understanding of planning for the future through investment accounts and retirement plans and comparing investment choices by analyzing rates of return and risk, while analyzing how diversification is one way to reduce investment risk, (7) recognizing that there are risks that can result in lost income, health, or identity and that those risks can be accepted, reduced, or transferred to others through the purchase of insurance. **Honors and Accelerated Level Course Note:** Accelerated courses require a greater demand on students through increased academic rigor. Academic rigor is obtained through the application, analysis, evaluation, and creation of complex ideas that are often abstract and multi-faceted. Students are challenged to think and collaborate critically on the content they are learning. Honors level rigor will be achieved by increasing text complexity through text selection, focus on high-level qualitative measures, and complexity of task. Instruction will be structured to give students a deeper understanding of conceptual themes and organization within and across disciplines. Academic rigor is more than simply assigning to students a greater quantity of work.

Link to CPALMS: <https://www.cpalms.org/PreviewCourse/Preview/22613>

Course Number: 2104310

Course Title: US Government

Credit: .5

Graduation Requirement: American Government

Description: The grade 9-12 United States Government course consists of the following content area strands: Geography, Civics and Government. The primary content for the course pertains to the study of government institutions and political processes and their historical impact on American society. Content should include, but is not limited to, the functions and purpose of government, the function of the state, the constitutional framework, federalism, separation of powers, functions of the three branches of government at the local, state and national level, and the political decision-making process..

Link to CPALMS: <http://www.cpalms.org/Public/PreviewCourse/Preview/633>

Course Number: 2104320

Course Title: US Government Honors

Credit: .5

Graduation Requirement: American Government

Description: United States Government - The grade 9-12 United States Government course consists of the following content area strands: Geography, Civics and Government. The primary content for the course pertains to the study of government institutions and political processes and their historical impact on American society. Content should include, but is not limited to, the functions and purpose of government, the function of the state, the constitutional framework, federalism, separation of powers, functions of the three branches of government at the local, state and national level, and the political decision-making process.

Honors/Advanced courses offer scaffolded learning opportunities for students to develop the critical skills of analysis, synthesis, and evaluation in a more rigorous and reflective academic setting. Students are empowered to perform at higher levels as they engage in the following: analyzing historical documents and supplementary readings, working in the context of thematically categorized information, becoming proficient in note-taking, participating in Socratic seminars/discussions, emphasizing free-response and document-based writing, contrasting opposing viewpoints, solving problems, etc. Students will develop and demonstrate their skills through participation in a capstone and/or extended research-based paper/project (e.g., history fair, participatory citizenship project, mock congressional hearing, projects for competitive evaluation, investment portfolio contests, or other teacher-directed projects).

Link to CPALMS: <https://www.cpalms.org/PreviewCourse/Preview/13351>

Course Number: 2100310

Course Title: US History

Credit: 1

Graduation Requirement: American History

Description: The grade 9-12 United States History course consists of the following content area strands: United States History, Geography, and Humanities. The primary content emphasis for this course pertains to the study of United States history from Reconstruction to the present day. Students will be exposed to the historical, geographic, political, economic, and sociological events which influenced the development of the United States and the resulting impact on world history. So that students can clearly see the relationship between cause and effect in historical events, students should have the opportunity to review those fundamental ideas and events which occurred before the end of Reconstruction.

Link to CPALMS: <https://www.cpalms.org/PreviewCourse/Preview/1723>

Course Number: 2100320

Course Title: US History Honors

Credit: 1

Graduation Requirement: American History

Description: United States History (U.S. History) 9-12 Course - The grade 9-12 United States History course consists of the following content area strands: United States History, Geography, and Humanities. The primary content emphasis for this course pertains to the study of United States history from Reconstruction to the present day. Students will be exposed to the historical, geographic, political, economic, and sociological events which influenced the development of the United States and the resulting impact on world history. So that students can clearly see the relationship between cause and effect in historical events, students should have the opportunity to review those fundamental ideas and events which occurred before the end of Reconstruction.

Honors/Advanced courses offer scaffolded learning opportunities for students to develop the critical skills of analysis, synthesis, and evaluation in a more rigorous and reflective academic setting. Students are empowered to perform at higher levels as they engage in the following: analyzing historical documents and supplementary readings, working in the context of thematically categorized information, becoming proficient in note-taking, participating in Socratic seminars/discussions, emphasizing free-response and document-based writing, contrasting opposing viewpoints, solving problems, etc. Students will develop and demonstrate their skills through participation in a capstone and/or extended research-based paper/project (e.g., history fair,

participatory citizenship project, mock congressional hearing, projects for competitive evaluation, investment portfolio contests, or other teacher-directed projects).

Link to CPALMS: <http://www.cpalms.org/Public/PreviewCourse/Preview/4495>

Course Number: 2109310

Course Title: World History

Credit: 1

Graduation Requirement: World History

Description: World History 9-12 Course - The grade 9-12 World History course consists of the following content area strands: World History, Geography and Humanities. This course is a continued in-depth study of the history of civilizations and societies from the middle school course, and includes the history of civilizations and societies of North and South America. Students will be exposed to historical periods leading to the beginning of the 21st Century. So that students can clearly see the relationship between cause and effect in historical events, students should have the opportunity to review those fundamental ideas and events from ancient and classical civilizations.

Link to CPALMS: <https://www.cpalms.org/PreviewCourse/Preview/4473>

Course Number: 2109320

Course Title: World History Honors

Credit: 1

Graduation Requirement: World History

Description: World History 9-12 Course - The grade 9-12 World History course consists of the following content area strands: World History, Geography and Humanities. This course is a continued in-depth study of the history of civilizations and societies from the middle school course, and includes the history of civilizations and societies of North and South America. Students will be exposed to historical periods leading to the beginning of the 21st Century. So that students can clearly see the relationship between cause and effect in historical events, students should have the opportunity to review those fundamental ideas and events from ancient and classical civilizations.

Honors/Advanced courses offer scaffolded learning opportunities for students to develop the critical skills of analysis, synthesis, and evaluation in a more rigorous and reflective academic setting. Students are empowered to perform at higher levels as they engage in the following: analyzing historical documents and supplementary readings, working in the context of thematically categorized information, becoming proficient in note-taking, participating in Socratic seminars/discussions, emphasizing free-response and document-based writing, contrasting opposing viewpoints, solving problems, etc. Students will develop and demonstrate their skills through participation in a capstone and/or extended research-based paper/project (e.g., history fair, participatory citizenship project, mock congressional hearing, projects for competitive evaluation, investment portfolio contests, or other teacher-directed projects).

Link to CPALMS: <http://www.cpalms.org/Public/PreviewCourse/Preview/13372>

Vocational Courses

Course Number: 8713010, 8713020, 8713030, and 8713040

Program Title: Air Conditioning, Refrigeration, and Heating Technology

Credit: 4

Graduation Requirement: Vocational

Description: The purpose of this program is to prepare students for employment or advanced training in the heating, air-conditioning and refrigeration and ventilation industry. The student should obtain EPA certification prior to leaving school in order to be employed in any job that requires work with refrigerants. This program offers a sequence of courses that provides coherent and rigorous content aligned with challenging academic standards and relevant technical knowledge and skills needed to prepare for further education and careers in the Architecture & Construction career cluster; provides technical skill proficiency, and includes competency-based applied learning that contributes to the academic knowledge, higher-order reasoning and problem-solving skills, work attitudes, general employability skills, technical skills, and occupation-specific skills, and knowledge of all aspects of the Architecture & Construction career cluster.

The content includes but is not limited to designing, testing and repairing heating, ventilation, air-conditioning and cooling (HVAC) systems.

Link to FLDOE: <https://www.fl DOE.org/core/fileparse.php/20062/urlt/8723000-2223.rtf>

Course Number: 8725010, 8725020, 8725030, and 8725040

Program Title: Architectural Drafting Secondary

Credit: 1 per course

Graduation Requirement: Vocational

Description: The purpose of this program is to prepare students for employment or advanced training in the architectural drafting industry. This program offers a sequence of courses that provides coherent and rigorous content aligned with challenging academic standards and relevant technical knowledge and skills needed to prepare for further education and careers in the Architecture and Construction career cluster; provides technical skill proficiency, and includes competency-based applied learning that contributes to the academic knowledge, higher-order reasoning and problem-solving skills, work attitudes, general employability skills, technical skills, and occupation-specific skills, and knowledge of all aspects of the Architecture and Construction career cluster. The content includes but is not limited to freehand sketching, drafting by hand and computer and 3D modeling specific to architectural drafting.

Additional Information relevant to this Career and Technical Education (CTE) program is provided at the end of this document.

Link to FLDOE: <https://www.fl DOE.org/academics/career-adult-edu/career-tech-edu/architecture-construction.stml>

Course Number: 9504110, 9504120, 9504130, 9504140, and 9504150

Program Title: Auto Maintenance /LT Repair

Credit: 1 per course

Graduation Requirement: Vocational

Description: This program offers a sequence of courses that provides coherent and rigorous content aligned with challenging academic standards and relevant technical knowledge and skills needed to prepare for further education and careers in the Transportation, Distribution and Logistics career cluster; provides technical skill proficiency, and includes competency-based applied learning that contributes to the academic knowledge, higher-order reasoning and problem-solving skills, work attitudes, general employability skills, technical skills, and occupation-specific skills, and knowledge of all aspects of the Transportation, Distribution and Logistics career cluster.

The content includes but is not limited to broad, transferable skills and stresses understanding and demonstration of the following elements of the Automotive industry; planning, management, finance, technical and product skills, underlying principles of technology, labor issues, community issues and health, safety, and environmental issues.

Link to FLDOE: <https://www.fl DOE.org/academics/career-adult-edu/career-tech-edu/curriculum-frameworks/2022-23-frameworks/transportation-distribution-logistics.stml>

Course Number: 8207310, 8212110, 8212120, 8212160, and 8216130

Program Title: Business Management and Administration

Credit: 1 per course

Graduation Requirement: Practical Art (8207310)

Description: This program offers a sequence of courses that provides coherent and rigorous content aligned with challenging academic standards and relevant technical knowledge and skills needed to prepare for further education and careers in technical digital media positions in the Information Technology career cluster; provides technical skill proficiency, and includes competency-based applied learning that contributes to the academic knowledge, higher-order reasoning and problem-solving skills, work attitudes, general employability skills, technical skills, and occupation-specific skills.

The content includes but is not limited to practical experiences in the implementation, management, and maintenance of advanced telecommunication environments associated with the creation, packaging, and delivery of digital media.

Link to FLDOE: <https://www.fldoe.org/academics/career-adult-edu/career-tech-edu/curriculum-frameworks/2022-23-frameworks/business-management-administration.stml>

Course Number: 8800510, 8800520, 8800530, and 8800540

Program Title: Culinary Arts

Credit: 1 per course

Graduation Requirement: Vocational (8800510 and 8800540); Practical Art (8800520 and 8800530)

Description: This program offers a sequence of courses that provides coherent and rigorous content aligned with challenging academic standards and relevant technical knowledge and skills needed to prepare for further education and careers in the Hospitality and Tourism career cluster; provides technical skill proficiency, and includes competency-based applied learning that contributes to the academic knowledge, higher-order reasoning and problem-solving skills, work attitudes, general employability skills, technical skills, and occupation-specific skills, and knowledge of all aspects of the Hospitality and Tourism career cluster.

The content includes but is not limited to all aspects of preparation, presentation, and serving of food; leadership, communication skills, employability skills, and safe/efficient work practices are also covered. This coursework prepares students for employment in the food service/hospitality industry. **Additional Information** relevant to this Career and Technical Education (CTE) program is provided at the end of this document.

Link to FLDOE: <https://www.fldoe.org/academics/career-adult-edu/career-tech-edu/curriculum-frameworks/2022-23-frameworks/hospitality-tourism.stml>

Course Number: 8201600

Program Title: Digital Media/Multimedia Design

Credit: 1

Graduation Requirement: Practical Art/Vocational

Description: The purpose of this program is to prepare students for work as multimedia artists and animators. This program offers a sequence of courses that provides coherent and rigorous content aligned with challenging academic standards and relevant technical knowledge and skills needed to prepare for further education and careers in the Arts, A/V Technology and Communication career cluster; provides technical skill proficiency, and includes competency-based applied learning that contributes to the academic knowledge, higher-order reasoning and problem-solving skills, work attitudes, general employability skills, technical skills, and occupation-specific skills, and knowledge of all aspects of the Arts, A/V Technology and Communication career cluster.

Link to FLDOE: <https://www.fldoe.org/academics/career-adult-edu/career-tech-edu/curriculum-frameworks/2022-23-frameworks/arts-a-v-technology-communication.stml>

Course Number: 8208110, 8208120, 8208330, and 8208340

Program Title: Game Simulation Animation Programming

Credit: 1 per course

Graduation Requirement: Practical Art

Description: This program offers a sequence of courses that provides coherent and rigorous content aligned with challenging academic standards and relevant technical knowledge and skills needed to prepare for further education and careers such as a Game/Simulation Designer, Game Programmer, and Game Software Developer in the Information Technology career cluster; provides technical skill proficiency, and includes competency-based applied learning that contributes to the academic knowledge, higher-order reasoning and problem-solving skills, work attitudes, general employability skills, technical skills, and occupation-specific skills, and knowledge of all aspects of the Information Technology career cluster.

The content includes but is not limited to practical experiences in game/simulation conceptualization, design, storyboarding, development methodologies, essential programming techniques, and implementation issues. Specialized programming skills involving advanced mathematical calculations and physics are also integrated into the curriculum.

Link to FLDOE: <https://www.fldoe.org/academics/career-adult-edu/career-tech-edu/curriculum-frameworks/2022-23-frameworks/info-technology.stml>

Course Number: 8417100, 8417110, and 8417211

Program Title: Health Science

Credit: 1 per course

Graduation Requirement: Vocational

Description: This program offers a sequence of courses that provides coherent and rigorous content aligned with challenging academic standards and relevant technical knowledge and skills needed to prepare for further education and careers in the Health Science career cluster; provides technical skill proficiency, and includes competency-based applied learning that contributes to the academic knowledge, higher-order reasoning and problem-solving skills, work attitudes, general employability skills, technical skills, and occupation-specific skills, and knowledge of all aspects of Health Science career cluster. At the end of the school year, students will sit for the Florida Certified Nursing Assistant certification exam.

Link to CPALMS: <http://www.cpalms.org/Public/PreviewCourseProgram/Preview?id=340&backend=true>

Course Number: 9007210, 9007220, 9007230, and 0200320

Program Title: Java Development and Programming

Credit: 1 per course

Graduation Requirement: Vocational

Description: This program offers a sequence of courses that provides coherent and rigorous content aligned with challenging academic standards and relevant technical knowledge and skills needed to prepare for further education and careers in the Information Technology career cluster; provides technical skill proficiency, and includes competency-based applied learning that contributes to the academic knowledge, higher-order reasoning and problem-solving skills, work attitudes, general employability skills, technical skills, and occupation-specific skills, and knowledge of all aspects of the Information Technology career cluster. The content includes but is not limited to the fundamentals of programming and software development; procedural and object-oriented programming; creating regular and specialized applications using the Java programming language, including testing, monitoring, debugging, documenting, and maintaining Java computer applications. In addition, students will learn the skills needed to master the Advanced Placement Computer Science Exam.

Link to FLDOE: <https://www.fldoe.org/academics/career-adult-edu/career-tech-edu/curriculum-frameworks/2022-23-frameworks/info-technology.stml>

Course Number: 8400320

Course Title: Medical Skills

Credit: 1

Graduation Requirement: Vocational

Description: This program offers a sequence of courses that provides coherent and rigorous content aligned with challenging academic standards and relevant technical knowledge and skills needed to prepare for further education and careers in the Health Science career cluster; provides technical skill proficiency, and includes competency-based applied learning that contributes to the academic knowledge, higher-order reasoning and problem-solving skills, work attitudes, general employability skills, technical skills, and occupation-specific skills, and knowledge of all aspects of the Health Science career cluster. The purpose of this program is to give students an opportunity to apply knowledge and skills related to the area of Health Science career cluster.

Link to CPALMS: <http://www.cpalms.org/Public/PreviewCourseProgram/Preview?id=736&backend=true>

Course Number: 8815120, 8203310, 8815130, 8300430

Course Title: Vystar Finance

Credit: 1 per course

Graduation Requirement: Vocational

Description: The purpose of this program is to prepare students for employment in the financial industry. This program is divided into two pathways, Finance and Global Finance. A student would complete the Finance Core then proceed into one of two pathways. This pathway leads to a concentration in Finance.

Link to FLDOE: <https://www.fldoe.org/core/fileparse.php/20062/urlt/8815100-2223.rtf>

Course Number: 9001110, 9001120, 9001130, 9001140

Course Title: Web Design

Credit: 1 per course⁵

Graduation Requirement: Practical Art

Description: This program offers a sequence of courses that provides coherent and rigorous content aligned with challenging academic standards and relevant technical knowledge and skills needed to prepare for further education and careers such as an Assistant Web Designer, a Web Designer, and Senior Web Designer in the Information Technology career cluster; provides technical skill proficiency, and includes competency-based applied learning that contributes to the academic knowledge, higher-order reasoning and problem-solving skills, work attitudes, general employability skills, technical skills, and occupation-specific skills, and knowledge of all aspects of the Information Technology career cluster.

The content includes but is not limited to operating system commands and web document development, design, promotion and scripting.

Link to FLDOE: <https://www.fldoe.org/academics/career-adult-edu/career-tech-edu/curriculum-frameworks/2022-23-frameworks/info-technology.stml>